



# K-600

## Gas detector with built in pump

### Technical Parameters

<b>Gas sampling method:</b>	Pumping
<b>Alarm methods:</b>	sound, light, vibration, curve display
<b>Working Temperature:</b>	-20°C-50°C
<b>Power:</b>	3.7V 3600mA rechargeable lithium battery
<b>Charging time:</b>	4-6 hours
<b>Display:</b>	2.4 inch colored LCD display
<b>Operating time:</b>	working continuously for at least 10 hours
<b>Explosion proof:</b>	Exib IIC T4 Gb

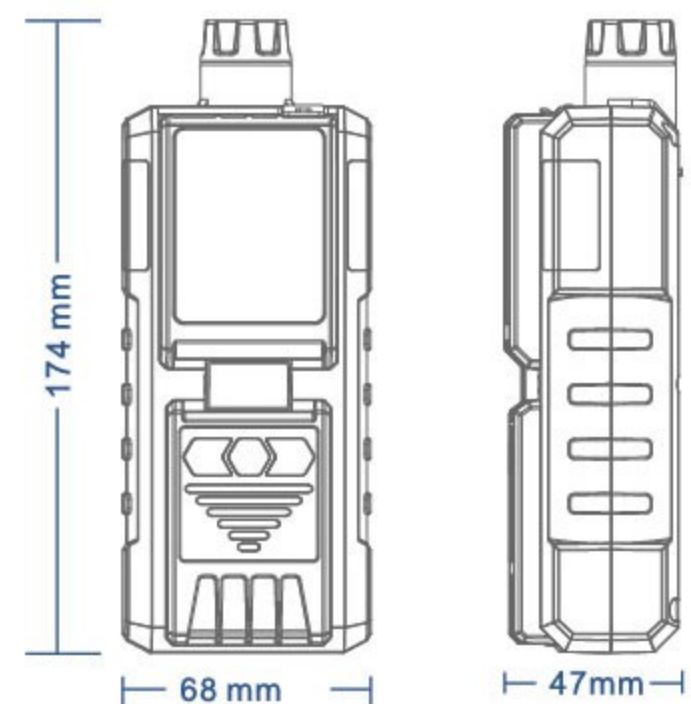

Size: 174x68x47mm

# K-600 Gas detector with built in pump

K-600 portable multi-gas detector with built-in pump is a new intelligent gas detector, which adopts an advanced integrated circuit, with standard intelligent level design technology, and proprietary digital analog hybrid communication technology. The detector is of excellent sensitivity and repeatability, which makes it very easy to use and maintain. Thus greatly meets the safety requirements of industrial sites with high reliability. The detector is made of high-strength engineering plastics, compound non-slip rubber, which is of high strength and good hand feeling. what's more, the detector is water-proof, dust-proof and explosion-proof.

It is widely used in petroleum, chemical, environmental, metallurgy, refining, gas transmission and distribution, biochemical medicine, agricultural and other industries.



Industrial sensor



Four alarm methods



Large capacity battery



Chinese-English switching



New UI



Anti-fire, water, dust

## Technique Datars

Gas	Range	Low Alarm	High Alarm	Deviation
EX	(0 ~ 100)%LEL	20%LEL	50%LEL	1%LEL
H2S	(0 ~ 100) ppm	10ppm	35ppm	1ppm
CO	(0 ~ 1000) ppm	50ppm	150ppm	1ppm
O2	(0 ~ 30)%vol	19.5%vol	23.5%vol	0.1%vol



Clean Rooms | Pharma | Hospital | HVAC | BulkDrugs | Chemicals | Heavy Machinery  
Hydraulics & Vacuum Industry | Green House | Server Room | Confined Space | Cold Storage