







Testboy[®] TB 317

Version 1.1

	Testboy®TB 317 operation manual	3
	Testboy®TB 317 Operating Instructions	16
	Testboy®TB 317 Mode d'emploi	29
	Testboy®TB 317 Manual de instrucciones	42
	Testboy®TB 317 Manuale dell'utente	55
	Testboy®TB 317 Operating handling suffering	68

Hints

safety instructions

**WARNING**

Sources of danger include, for example, mechanical parts that can cause serious injuries to people.
There is also a risk to objects (e.g. damage to the device).

**WARNING**

Electric shock can lead to death or serious injuries to people and can endanger the functioning of objects (e.g. damage to the device).

**WARNING**

Never aim the laser beam at the eye directly or indirectly through reflective surfaces. Laser radiation can cause irreparable damage to the eye. When taking measurements near people, the laser beam must be deactivated.

General safety instructions

**WARNING**

For safety and approval reasons (CE), unauthorized conversion and/or modification of the device is not permitted. To ensure safe operation of the device, you must strictly observe the safety instructions, warnings and the chapter "Intended use".

**WARNING**

Before using the device, please note the following information:

- | Avoid operating the device near electric welding machines, induction heaters and other electromagnetic fields.
 - | After abrupt temperature changes, the device must be adjusted to the new ambient temperature for approx. 30 minutes before use to stabilize the IR sensor.
 - | Do not expose the device to high temperatures for a long time. Avoid dusty and humid environmental conditions.
- Measuring devices and accessories are not toys and do not belong in the hands of children! In commercial facilities, the accident prevention regulations of the Association of Commercial Professional Associations for electrical systems and equipment must be observed.



Please note the five safety rules:

- 1**Unlock
- 2**Secure against being switched on again
- 3**Determine the absence of voltage (the absence of voltage must be determined at 2 poles)
- 4**Ground and short circuit
- 5**Cover adjacent live parts

Intended Use

The device is only intended for the applications described in the operating instructions. Any other use is not permitted and can lead to accidents or destruction of the device. These applications result in the immediate invalidation of any guarantee and warranty claims of the operator against the manufacturer.



To protect the device from damage, please remove the batteries if the device is not being used for a long period of time.



We assume no liability for property damage or personal injury caused by improper handling or non-observance of the safety instructions. In such cases, any warranty claim is void. An exclamation mark in a triangle indicates safety instructions in the operating instructions. Read the instructions completely before using. This device is CE tested and therefore meets the required guidelines.

Rights reserved to change specifications without prior notice ©
2022 Testboy GmbH, Germany.

Disclaimer



Any damage caused by failure to follow the instructions will void the warranty! We assume no liability for any consequential damage resulting from this!

Testboy is not liable for any damage resulting from | failure to follow the instructions,

| Changes to the product not approved by Testboy or |
Spare parts not manufactured or approved by Testboy | The
influence of alcohol, drugs or medication can result.

Accuracy of the operating instructions

This operating manual was created with great care. No liability is assumed for the accuracy and completeness of the data, illustrations and drawings. Subject to changes, misprints and errors.

disposal

Dear Testboy customer, by purchasing our product you have the opportunity to return the device to suitable collection points for electronic waste at the end of its life cycle.



WEEE regulates the return and recycling of old electrical equipment. Manufacturers of electrical appliances are obliged to take back and recycle electrical appliances that are sold free of charge. Electrical devices may then no longer be disposed of in the "normal" waste streams. Electrical devices must be recycled and disposed of separately. All devices covered by this policy are marked with this logo.

Disposal of used batteries



You as the end user are legally (**Battery law**) obliged to return all used batteries and accumulators; **Disposal with household waste is prohibited!**

Batteries/rechargeable batteries containing harmful substances are marked with the following symbols, which indicate that disposal with household waste is prohibited.

The names for the crucial heavy metal are: **CD**= Cadmium, **Ed**=Mercury, **Pb**=Lead.

You can hand in your used batteries/accumulators free of charge at the collection points in your community or wherever batteries/accumulators are sold!

Quality certificate

All quality-relevant activities and processes carried out within Testboy GmbH are permanently monitored by a quality management system. Testboy GmbH further confirms that the testing equipment and instruments used during calibration are subject to permanent testing equipment monitoring.

Declaration of Conformity

The product meets the latest guidelines. Further information can be found at www.testboy.de

service

Introduction

The test boy®TB 317 is a universal multimeter. The measuring device is manufactured according to the latest safety regulations and ensures safe and reliable work. The multimeter is a valuable aid for all standard measuring tasks in the craft or industrial sector as well as for electronics engineers. The TB 317 multimeter is also particularly suitable for outdoor use due to its CAT IV 1000V classification.

Safety measures

The TB 317 left the factory in perfect safety condition. To maintain this condition, the user must observe the safety instructions in these instructions.



Danger!

Only use the included safety test leads or equivalent test leads that meet the same measurement category.

To avoid electric shock, precautions must be observed when operating with voltages greater than 120 V (60 V) DC or 50 V (25 V) rms. AC is working. According to DIN VDE, these values represent the limit of the voltages that can still be touched. (Values in brackets apply to medical or agricultural areas, for example)

Before each measurement, make sure that the measuring lines and the test device are in perfect condition.

The measuring lines and test probes may only be touched using the handles intended for this purpose. Touching the test tips must be avoided under all circumstances.



The test device may only be used in the specified measuring ranges.



Caution !

Before each use, the device must be checked to ensure that it is functioning properly (e.g. on a known voltage source, see also DIN VDE 0105, Part 1).

Switch, button and socket explanation

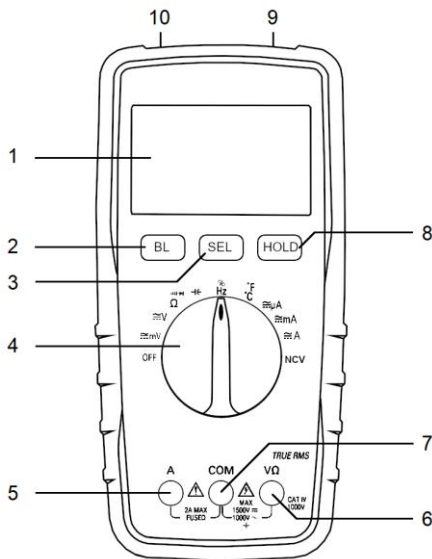

(1) Display

(2) BL button

When you press the button, the background/Measuring point lighting turned on.

(3) SEL button

This button allows the device to switch categories.

(4) Measuring function selection switch

Turns the device on. Measuring function is selected depending on the switch position.

(5) Measuring socket A

Measuring instruments to be used socket for current measurements.

(6) V/Ω measuring socket

Measuring instruments to be used socket for voltage/Resistance measurements.

(7) COM/Ground socket

(8) HOLD button
This button allows you to save the currently displayed value.

(9) Measuring point lighting

Measuring point lighting located at the front for working in dark areas.

(10) NCV sensor

This area detects live cables without contact.

DC voltage measurement / V=

Set the appropriate range using the selector switch. The black measuring line with the "COM" socket and the red measuring line with the "V/Ω" Connect the socket. Connect the measuring cables to the test object. Read the measurement result from the display. The polarity of the voltage is also displayed.

measuring rich	resolution	input resistance	overvoltage protection	accuracy
600mV	0.1mV	> 1000 MΩ	1500 Vrms	±0.8% of measuring range + 4 digits
6V	1mV	> 10 MΩ		
60V	10mV			
600V	100mV			
1000 B	1V			±1% of measurement range + 5 digits

AC voltage measurement / V~

Set the appropriate range using the selector switch. "SEL" Press the " " button and select AC. The black measuring cable with the "COM" socket and the red measuring line with the "V/Ω" Connect the socket. Connect the measuring lines to the test object. Read the measurement result from the display.

measuring rich	resolution	input resistance	overvoltage protection	accuracy
600mV	0.1mV	> 1000 MΩ	1500 Vrms	±0.8% of measuring range + 5 digits
6V	1mV	> 10 MΩ		
60V	10mV			
600V	100mV			
1000 B	1V			±1.5% of measuring range + 5 digits

Frequency range: 10Hz - 1.2kHz

Direct current measurement / A=

Set the appropriate range using the selector switch. The black measuring line with the "COM" socket and the red measuring line with the "A" Connect the socket. Connect the measuring cables to the test object and read the measurement result from the display. The current direction is also indicated by a sign.

Measuring range	resolution	overvoltage protection	accuracy
600 μ A	0.1 μ A	200mA self-reset safety tion.	$\pm 1.2\%$ of measuring range + 3 digits
6000 μ A	1 μ A		
60mA	10mA		
600mA	100 μ A		
10A	10mA	10A/1000V	$\pm 2.0\%$ of measuring range + 10 digits

Observe the maximum duty cycle in the 10 A range!

AC current measurement / A~

Set the appropriate range using the selector switch. "SEL"- Press the button and select AC. The black measuring line with the "COM" socket and the red measuring line with the "A" Connect the socket. Connect the measuring lines to the test object and read the measurement result from the display.

Measuring range	resolution	overvoltage protection	accuracy
600 μ A	0.1 μ A	200mA self-reset safety tion.	$\pm 1.5\%$ of measuring range + 3 digits
6000 μ A	1 μ A		
60mA	10mA		
600mA	100 μ A		
10A	10mA	10A/1000V	$\pm 3.0\%$ of measuring range + 10 digits

Frequency range: 10Hz - 1.2kHz



Resistance measurement / Ω

Set the appropriate range using the selector switch. The black measuring line with the "COM" socket and the red measuring line with the "V/ Ω " Connect the socket. Connect the measuring cables to the test object and read the measurement result from the display.

Measuring range	resolution	accuracy
600 Ω	0.1 Ω	$\pm 1.2\% + 5$ digits
6K Ω	1 Ω	
60K Ω	10 Ω	
600K Ω	100 Ω	
6M Ω	1K Ω	
60M Ω	10K Ω	$\pm 2.0\%$ + 10 digits

Surge protection: 250V RMS Open
circuit voltage: 1.2V



Diode test

Open the selector switch  /  Set. "SEL" Press the " " button twice. The black one Measuring line with the "COM" socket and the red measuring line with the "V/ Ω " Connect the socket. Connect the measuring lines to the test object (red measuring line = anode, black measuring line = cathode). The forward voltage is displayed.

Measuring range	resolution	Advertisement
	1mV	Forward voltage

Surge protection: 250V RMS Open
circuit voltage: 1.0V

Continuity test

With the selector switch on "  /  Set. "SEL" Press the " " button. The black one Measuring line with the "COM" socket and the red measuring line with the "V/ Ω " Connect the socket. Connect the measuring lines to the test circuit.

Measuring range	function
	The integrated buzzer reports continuity below 50 Ω

Open circuit voltage: 1.0V

temperature

Set the selector switch to "°C". Connect a Type-K temperature sensor (nickel-chrome / nickel) to the sockets "V/Ω" and "COM". Read the measurement result from the display.

Measuring range	resolution	accuracy
- 20 to 0°C	1°C	±2% + 3 digits
0 to 400°C		±1% + 2 digits
400 to 1000°C		±2% + 2 digits
- 4 to 32°F	1°F	±2% + 6 digits
32 to 752°F		±1% + 4 digits
752 to 1832°F		±2% + 4 digits

Capacity measurement / F

Set the selector switch to "  ". Set the black measuring line with the "COM"-socket and the red measuring line with the "V/Ω". Connect the socket. Connect the measuring leads to the test circuit and read the measurement result from the display.

Measuring range	resolution	accuracy
60nF	10pF	± 4% + 3 digits
600nF	100pF	
6μF	1nF	
60μF	10nF	
600μF	100nF	
6mF	1μF	
60mF	10μF	



Discharge the capacitors before each measurement.

frequency

Set the selector switch to "Hz" Set the black measuring line with the "COM" socket and the red measuring line with the "V/Ω" Connect the socket. Connect the measuring leads to the test circuit and read the measurement result from the display.

Measuring range	resolution	accuracy
10Hz	0.001Hz	±1% + 5 digits
100Hz	0.01 kHz	
1 kHz	0.1Hz	
10kHz	1Hz	
100kHz	10Hz	
1 MHz	100Hz	
10MHz	1 kHz	

Surge protection: 250V RMS

duty cycle

Set the selector switch to "%Hz" set. "SEL" Press the " " button. Connect the black measuring line with the "COM" socket and the red measuring line with the "V/Ω" Connect the socket. Connect the measuring leads to the test circuit and read the measurement result from the display.

Measuring range	resolution	accuracy
0 – 99%	0.1%	±3% + 2 digits

Surge protection: 250V RMS

Automatic shutdown

After approx. 15 minutes the device switches off (APO). By holding down the "HOLD"- button during switching on, the Auto Power Off function is switched on. If the button "SEL" If you hold down the button for a longer period of time while switching on, the Auto Power Off function is switched off.

Backlight

By pressing the "BL" button turns on the backlight.

The lighting switches off automatically after approx. 15 seconds. If the button is pressed for a longer period of time, the measuring point lighting is switched on.

Memory function (HOLD)

The display may not be read correctly in difficult measuring positions. By pressing the "HOLD" button, the current measured value is frozen and can then be easily read.

By pressing the "HOLD" button takes you back to normal measuring operation.

True RMS

When measuring non-sinusoidal waveforms, fewer measurement errors occur when using the True RMS function than when using conventional measurement methods. Sinusoidal and non-sinusoidal signals can be measured precisely with the True RMS function.

maintenance

The device does not require any special maintenance when operated according to the operating instructions.

cleaning

If the device has become dirty through daily use, the device can be cleaned with a damp cloth and some mild household cleaner. Never use harsh cleaners or solvents for cleaning.

Battery replacement

The battery change is necessary when the battery symbol  appears on the display. Before the measuring lines must be separated from the device!

Remove screws on the back, open the battery compartment and remove the discharged battery. Insert new batteries (1 × 9V block). Put the battery compartment cover on and screw it on.



Only use the specified batteries!

Batteries do not belong in household waste! Observe the legal disposal regulations!

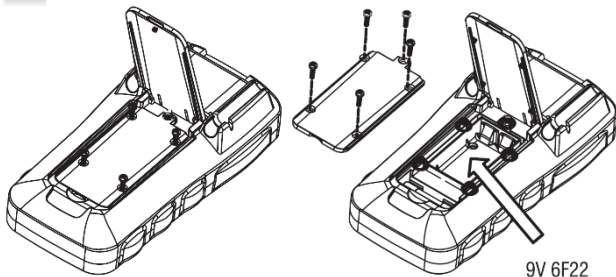

Fuse change

Remove screws on the back, open battery compartment, remove holster, remove housing screws and fuse. Insert new fuse (F 10A). Reassemble and screw together in reverse order.



Only use the specified fuses!

The following measurement categories are defined according to the EN 61010-1 standard:

Measurement category CAT II

Measurements on circuits that are electrically connected directly to the network, via plugs in the home, office and laboratory.

Measurement category CAT III

Measurements on the building installation: Stationary consumers, distribution connection, devices fixed to the distributor.

Measurement category CAT IV

Measurements at the source of the low voltage installation: meter, primary surge protector, main connection

Technical data

DC voltage measurement	0V~1000V
AC voltage measurement	0V~1000V
Direct current measurement	0A ~ 10A
AC current measurement	0A ~ 10A
Resistance measurement	0Ω ~ 60MΩ
Continuity test	0Ω ~ 50Ω
Temperature measurement	- 200°C ~ 1300°C - 328°F ~ 2372°F
Frequency measurement	10Hz ~ 10MHz
Fuses	F 200 mA self-resetting (maintenance-free) and F 10 A (10.3 x 38 mm)
Polarity display	automatically
Overflow indicator	"OL" is displayed
Overvoltage category	CAT IV 1000V
Power supply	1 x 9V Block
operating temperatur	0°C to 40°C
Storage temperature	- 10°C to 50°C
Dimensions	193 × 95 × 57mm
Weight	500 g including battery

information

Safety information



WARNING

Sources of danger include, for example, mechanical parts that can cause serious injuries.

Objects are also at risk (eg damage to the instrument).



WARNING

An electric shock can result in death or serious injuries and endanger the function of objects (eg damage to the instrument).



WARNING

Never point the laser beam at eyes, either directly or indirectly via a reflective surface. Laser radiation can cause irreparable damage to eyes. The laser beam must be deactivated when conducting measurements close to people.

General safety information



WARNING

Unauthorized modification and/or changes to the instrument are not permitted for reasons of safety and approval (CE). In order to ensure safe and reliable operation of the instrument, you must always observe the safety information, warnings and the section "Intended use".



WARNING

Observe the following information before using the instrument:

- | Avoid operating the instrument near electric welding equipment, induction heaters or other electromagnetic fields.
 - | After abrupt temperature fluctuations, the instrument must be allowed to adjust to the new ambient temperature for approx. 30 minutes before use, in order to stabilize the IR sensor.
 - | Do not expose the instrument to high temperatures for a long period of time.
 - | Avoid dusty and humid environments.
 - | Measuring instruments and their accessories are not toys, and must be kept out of the reach of children!
 - | When working in industrial facilities, observe the accident prevention regulations for electrical systems and equipment as established by the employers' liability insurance association.
-



Please observe the five safety rules:

- 1** Disconnect
- 2** Secure against reactivation
- 3** Ensure isolation from the power supply (check that there is no voltage on both poles)
- 4** Earth and short circuit
- 5** Cover adjacent live parts

Intended use

The instrument is only intended for use in the applications described in the operating instructions. Any other usage is forbidden and can result in accidents or destruction of the instrument. Any such usage will immediately void all guarantee and warranty claims on the part of the operator against the manufacturer.



Remove the batteries if the instrument is not in use for a long period of time; this will protect the instrument against damage.



We shall not accept any liability for damage or injury resulting from improper handling or non-compliance with the safety information. Any warranty claim will be voided in such cases. An exclamation mark in a triangle indicates safety information in the operating instructions. Read all instructions through before commissioning. This instrument is CE-approved and thus fulfills the required directives.

We reserve the right to alter specifications without prior notice © 2022 Testboy GmbH, Germany.

Disclaimer



The warranty claim is voided in cases of damage caused by failure to observe the instructions! We shall not accept any liability for the resulting damage!

Testboy does not accept responsibility for damage resulting from |
Failure to observe the operating instructions
| Changes to the product that have not been approved by Testboy | Spare
parts that have not been manufactured or approved by Testboy | The
consumption of alcohol, narcotics or medicine

Correctness of the operating instructions

These operating instructions have been compiled with considerable care and attention. No guarantee is given that the data, figures and drawings are complete or correct. Subject to changes, printing mistakes and errors.

Disposal

Dear Testboy customer, Purchasing our product gives you the option of returning the instrument at the end of its lifespan to suitable collection points for waste electrical equipment.



The WEEE directive regulates the return and recycling of old electrical appliances. Manufacturers of electrical appliances are obliged to take back and recycle all electrical appliances free of charge. Electrical appliances may then no longer be disposed of through "conventional" waste disposal channels. Electrical appliances must be recycled and disposed of separately. All equipment subject to this directive is marked with this logo.

Disposal of used batteries



As an end user, you are legally obliged (**battery law**) to return all used batteries; **disposal in domestic waste is prohibited!**

Batteries containing contaminant material are marked with this symbol indicating that they must not be disposed of in domestic waste.

The abbreviations used for the respective heavy metals are: **CD**=cadmium, **Ed**=mercury, **Pb**=lead.

You can return your used batteries free of charge to municipal collection points or anywhere where batteries are sold!

Certificate of quality

All quality-related activities and processes performed by Testboy GmbH are subject to continual monitoring within the framework of a quality management system. Testboy GmbH confirms that the testing equipment and instruments used during the calibration process are subject to a continual monitoring process.

Declaration of conformity

The product conforms to the most recent directives. For further information, go to www.testboy.de

surgery

Introduction

The Testboy®TB 317 is a universal multimeter. This measuring instrument has been manufactured to the latest safety specifications, and guarantees safe and reliable operation. The multimeter is a valuable aid for all standard measurement tasks in trade and industry, as well as for electronics engineers. With its CAT IV 1000V classification, the TB 317 multimeter is ideal for use outdoors too.

Safety precautions

The TB 317 left the factory with its safety features in perfect operating condition. The user must observe the safety information contained in these instructions in order to maintain this condition.



Deposit!

Only use the safety test leads included in the scope of delivery or equivalent leads that comply with the same measurement category.

In order to avoid an electric shock, comply with the precautions when working with voltages greater than 120 V (60 V) DC or 50 V (25 V) eff. AC. These values represent the limits of safe-to-touch voltages in accordance with DIN VDE. (Values given in brackets apply eg to the medical or agricultural sectors)

Before taking each measurement, ensure that the test leads and the test instrument are in perfect operating condition.

The test leads and probes must only be handled using the grips provided. Avoid touching the probes under any circumstances.



The test instrument may only be used for the measurement ranges specified.



Attention!

Before use, check that the instrument is functioning correctly (eg using a known voltage source, also see DIN VDE 0105, part 1).

Explanation of switches, buttons and jacks

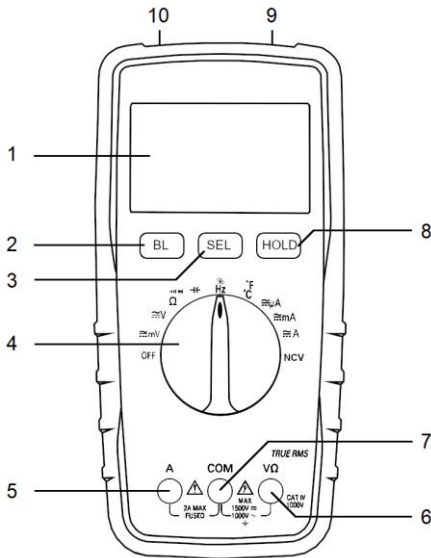

(1) Display

(2) BL button

Pressing this button switches on backlighting/measurement location lighting.

(3) SEL button

This button can be used to switch the instrument between categories.

(4) Measurement function selection switch

Switches the instrument on. The measurement function is selected depending on the switch position.

(5) Measurement jack A

Measurement jack to be used for measuring current.

(6) Measurement jack V/Ω

Measurement jack to be used for measuring voltage/resistance.

(7) COM/earth jack

(8) HOLD button

This button enables the currently displayed value to be saved.

(9) Measurement location lighting

Measurement location lighting located at the front for working in dark spaces.

(10) NCV sensor

This button enables contactless detection of live lines.

DC voltage measurement / V=

Set the appropriate range using the selector switch. Connect the black test lead with the "COM" jack and the red test lead with the "V/Ω" jack. Connect test leads to the test object. Read off measurement result from the display. The voltage polarity is also displayed.

Measurement range	resolution	Input resistance	Overvoltage protection	Accuracy
600mV	0.1mV	> 1000 MΩ	1500 Vrms	±0.8% of the measurement range + 4 digits
6V	1mV	> 10 MΩ		
60V	10mV			
600V	100mV			
1000 B	1V			±1% of the measurement range + 5 digits

AC voltage measurement / V~

Set the appropriate range using the selector switch. Press the "SEL" button and select AC. Connect the black test lead with the "COM" jack and the red test lead with the "V/Ω" jack. Connect test leads to the test object. Read off measurement result from the display.

Measurement range	resolution	Input resistance	Overvoltage protection	Accuracy
600mV	0.1mV	> 1000 MΩ	1500 Vrms	±0.8% of the measurement range + 5 digits
6V	1mV	> 10 MΩ		
60V	10mV			
600V	100mV			
1000 B	1V			±1.5% of the measurement range + 5 digits

Frequency range: 10Hz - 1.2kHz

DC current measurement / A=

Set the appropriate range using the selector switch. Connect the black test lead with the "COM" jack and the red test lead with the "A" Jack. Connect the test leads with the test object and read off the measurement result from the display. The direction of current is indicated by the sign.

Measurement range	resolution	Overvoltage protection	Accuracy
600µA	0.1 µA	200mA Self-resetting fuse.	±1.2% of the measurement range + 3 digits
6000µA	1 µA		
60mA	10mA		
600mA	100µA		
10A	10mA	10A/1000V	±2.0% of the measurement range + 10 digits

In the 10 A range, observe the maximum duty cycles!

AC current measurement / A~

Set the appropriate range using the selector switch. Press the "SEL" button and select AC. Connect the black test lead with the "COM" jack and the red test lead with the "A" Jack. Connect the test leads with the test object and read off the measurement result from the display.

Measurement range	resolution	Overvoltage protection	Accuracy
600µA	0.1 µA	200mA Self-resetting fuse.	±1.5% of the measurement range + 3 digits
6000µA	1 µA		
60mA	10mA		
600mA	100µA		
10A	10mA	10A/1000V	±3.0% of the measurement range + 10 digits

Frequency range: 10Hz - 1.2kHz

Resistance measurement / Ω



Set the appropriate range using the selector switch. Connect the black test lead with the "COM" jack and the red test lead with the "V/ Ω " jack. Connect the test leads with the test object and read off the measurement result from the display.

Measurement range	resolution	Accuracy
600 Ω	0.1 Ω	±1.2% + 5 digits
6K Ω	1 Ω	
60K Ω	10 Ω	
600K Ω	100 Ω	
6M Ω	1K Ω	±2.0% + 10 digits
60M Ω	10K Ω	

Overvoltage protection: 250 V RMS

Off-load voltage: 1.2 V

Diode test



Set the selector switch to  / . Press the "SEL" button x 2. Connect the black test lead with the "COM" jack and the red test lead with the "V/ Ω " jack. Connect the test leads with the test object (red test lead = anode, black test lead = cathode). The forward voltage is displayed.

Measurement range	resolution	display
	1mV	Forward voltage

Overvoltage protection: 250 V RMS

Off-load voltage: 1.0 V

Continuity test

Set the selector switch to "  / . Press the "SEL" button. Connect the black test lead with the "COM" jack and the red test lead with the "V/ Ω " jack. Connect test leads to the test circuit.

Measurement range	Function
	The integrated buzzer signals continuity less than 50 Ω

Off load voltage: 1.0V

Temperature

Set the selector switch to "°C". Connect a type-K temperature sensor (nickelchrome/nickel) to the "V/Ω" and "COM" jacks. Read off measurement result from the display.

Measurement range	resolution	Accuracy
- 20 to 0 °C	1°C	±2% + 3 digits
0 to 400°C		±1% + 2 digits
400 to 1000 °C		±2% + 2 digits
- 4 to 32°F	1°F	±2% + 6 digits
32 to 752°F		±1% + 4 digits
752 to 1832°F		±2% + 4 digits

Capacitance measurement / F

Set the selector switch to "  ". Connect the black test lead with the "COM" jack and the red test lead with the "V/Ω" jack. Connect the test leads with the test object and read off the measurement result from the display.

Measurement range	resolution	Accuracy
60nF	10pF	± 4% + 3 digits
600nF	100pF	
6μF	1nF	
60μF	10nF	
600μF	100nF	
6mF	1μF	
60mF	10μF	



Discharge the capacitors before every measurement.

Frequency

Set the selector switch to "Hz". Connect the black test lead with the "COM" jack and the red test lead with the "V/Ω" jack. Connect the test leads with the test object and read off the measurement result from the display.

Measurement range	resolution	Accuracy
10Hz	0.001Hz	±1% + 5 digits
100Hz	0.01kHz	
1kHz	0.1Hz	
10kHz	1Hz	
100kHz	10Hz	
1MHz	100Hz	
10MHz	1kHz	

Overvoltage protection: 250V RMS

Duty cycle

Set the selector switch to "%/Hz". Press the "SEL" button. Connect the black test lead with the "COM" jack and the red test lead with the "V/Ω" jack. Connect the test leads with the test object and read off the measurement result from the display.

Measurement range	resolution	Accuracy
0 - 99%	0.1%	±3% + 2 digits

Overvoltage protection: 250V RMS

Automatic switch off

The instrument switches off after approx. 15 minutes (APO). Pressing and holding down the "HOLD" button switches on the Auto Power Off function. If the "SEL" button is held down while switching on, the Auto Power Off function is switched off.

Backlighting

Pressing the "BL" button switches on the backlighting.

The lighting switches off automatically after approx. 15 seconds. When the button is pressed and held down, measurement location lighting is switched on.

Save function (HOLD)

In difficult measurement positions, it may not be possible to read the display correctly. Pressing the "HOLD" button freezes the real reading, which can then be read off when convenient. Pressing the "HOLD" button again returns the instrument to normal measuring mode.

True RMS

When using the True RMS function to measure non-sinus wave forms, small measurement errors can occur compared with conventional measurement procedures.

Sine-form and non-sinus form signals can be accurately measured using the True RMS function.

Maintenance

The instrument does not require special maintenance when used as specified in these operating instructions.

Cleaning

Use a damp cloth and mild household detergent to clean the instrument should it become soiled through daily use. Never use harsh cleaning agents or solvents to clean the instrument.

Battery replacement

Replace the batteries when the battery symbol lead  appears on the display. Remove the test the instrument before changing the batteries!

Remove the screws at the back, open the battery compartment and remove the discharged battery. Insert new batteries (1 x 9V block). Refit the battery compartment lid and secure with screws.



Only use the batteries specified!

Batteries must not be disposed of in domestic waste! Observe the statutory regulations pertaining to disposal!

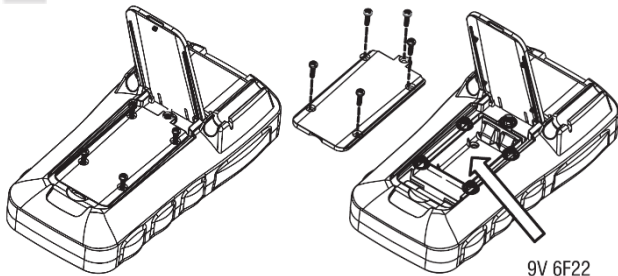

Changing the fuse

Remove the screws at the back, open the battery compartment, remove the holster, and remove the housing screws and fuse. Insert a new fuse (F 10A). Reassemble in the reverse order and secure with screws.



Only use the fuses specified!

The following measurement categories have been defined in accordance with EN 61010-1:

Measurement category CAT II

Measurements on circuits that are directly wired to the mains, via plugs in the home, office and laboratory.

Measurement category CAT III

Measurements on building installations: fixed consumers, distributor connection, equipment fitted permanently to the distributor.

Measurement category CAT IV

Measurements at the source of the low voltage installation: meters, primary surge protection, mains connection

Technical data

DCV measurement	0V~1000V
AC V measurement	0V~1000V
DC measurement	0A ~ 10A
AC measurement	0A ~ 10A
Resistance measurement	0Ω ~ 60MΩ
Continuity testing	0Ω ~ 50Ω
Temperature measurement	- 200°C ~ 1300°C - 328°F ~ 2372°F
Frequency measurement	10Hz ~ 10MHz
Fuses	F 200 mA self-resetting (maintenance-free) and F 10 A (10.3 x 38 mm)
Polarity indicator	Automatic
Overload indicator	"OL" is displayed
Overvoltage category	CAT IV 1000V
Power supply	1 x 9V block
Operating temperature	0°C to 40°C
Storage temperature	- 10°C to 50°C
Dimensions	193 × 95 × 57mm
Weight	500 g including battery

Consignments

Consignments of security



AVERTISSEMENT

Les sources de danger sont, p. ex., les éléments mécaniques pouvant causer de graves blessures aux personnes.

Il existe également des dangers pour les biens matériels (p. ex. un endommagement de l'appareil).



AVERTISSEMENT

The electrocution can entraîner the death or the injuries graves et nuire au fonctionnement de biens matériels (p. ex. en endommageant l'appareil).



AVERTISSEMENT

The focus is on the rayon laser directement ou indirectement vers les yeux en l'orientant sur une surface réfléchissante. The laser radiation can cause irreversible lesions in the eyes. The rayon laser does not deactivate the measurements effectuées à proximité de personnes.

Consignes generales de sécurité



AVERTISSEMENT

Pour des raisons de sécurité et d'homologation (CE), it is between the transformer and/or modifier of the device without authorization. Afin de garantir un fonctionnement sûr de l'appareil, les consignes de sécurité et avertissements, ainsi que le chapitre « Utilization conforme » doivent imperative être respectés.



AVERTISSEMENT

Respect les consignes suivantes prior to the use of the equipment:

- | Éviter d'utiliser l'appareil à proximité de postes de soudure électriques, de chauffages à induction et d'autres champs électromagnétiques.
- | After a change in the temperature, the device is in the same place. 30 minutes at the new ambient temperature before using it to permanently stabilize the IR detector.
- | Ne pas soumettre l'appareil à des températures élevées pendant des périodes prolongées.
- | Éviter les conditions ambiantes poussiéreuses and humides.
- | The devices for measuring and accessories are not included in the toys and are available at the same time as the portée des enfants!

Dans les établissements industriels, les règlements de prévention des accidents de l'Association des syndicats professionnels en charge des installations et équipements électriques doivent être respectés.



Respect the following security regulations:

- 1 Débrancher l'appareil
- 2 Empêcher son redémarrage
- 3 Le mettre hors tension (la mise hors tension doit être constatée sur les 2 pôles)
- 4 Mettre à la terre et court-circuiter
- 5 Couvrir les éléments sous tension voisins

Utilization conforme

The device is exclusive and conçu pour les applications décrites dans the manual d'utilisation. Apart from its use, it is intermediary and can cause accidents or damage to the equipment. Ces applications entraînent l'extinction immédiate de la guaranty dont bénéficie the utilisateur vis-à-vis the fabricant.



Afin de protector l'appareil againstre d'éventuels damages, retirer les piles en cas de non-utilisation prolongée.



Nous n'endossons aucune responsabilité en cas de damages matériels ou corporels résultant d'une manipulation inappropriée or du non-respect des consignes de sécurité. The guarantee is in these cases. A point of exclamation in a triangle renvoie aux consignes de sécurité du present manual d'utilisation. Lire les instructions in its intégralité prior to the mise en service. This appareil a fait l'objet d'un contrôle CE et satisfait aux normes pertinentes.

Nous nous réservons the power of modifier les specifications de cet appareil sans préavis. © 2022 Testboy GmbH, Allemagne.

Exclusion of responsibility



The guarantee s'éteint en cas de damages résultant du non-respect du présent manuel d'utilisation ! Nous n'endossons aucune responsabilité pour les damages consécutifs en résultant !

Testboy n'assume also responsabilité pour les damages résultant: | you don't respect you present manuel d'utilisation,

| de modifications apportées au product without the agreement of Testboy,

| The use of parts can be changed without being manufactured or homologated for Testboy,

| de l'influence de l'alcool, de drugs or de medications.

Exactitude du manual d'utilisation

These service instructions are redistributed and have a larger size. Nous n'endossons also responsabilité pour l'exactitude et l'intégralité des données, illustrations et schémas qu'elles continennent. Sous réserve de modifications, d'erreurs d'impression et d'erreurs.

Elimination

The client Testboy, who accepts our product, has the possibility of depositing the product in the center of the collection for electrical devices.



The directive WEEE regulates the reprise and recycling of electrical appliances in use. The fabricators of electrical appliances have the tenus of reprendre and recycler gratuitement of the electrical appliances sold. The electrical devices are not only available, but also have jets with "normal" déchets. The electrical appliances can be recycled and eliminated separately. All devices have this directive portent ce logo.

Elimination of piles used



If you use it, you can use it legally (**loi allemande sur les piles**) tenu de déposer toutes vos piles and batteries used dans des centers agréés ; **The jet cell is interconnected with the ménagères orders!**

The piles and batteries containing substances toxics portent les symboles illustrés ci-contre, indiquant qu'il est interdit de les jeter dans les ordures ménagères. The symbols of the métaux lourds concernés sont:

CD=Cadmium, **Ed**=mercury, **Pb**=seal.

You can have your piles and batteries used in a community collection center or part of the piles/batteries that are sold!

Certificate of quality

The ensemble of activities and processes performs a high quality performance on the Testboy GmbH company and is constantly controlled by a quality control system. The company Testboy GmbH confirms that the control equipment and instruments used in the equipment are also permanent controls.

Declaration of conformity

The product conforms to the dernières directives. Plus d'information on www.testboy.de

Utilization

Introduction

Le Testboy®TB 317 is a universal multimeter. This apparatus de mesure respects the prescriptions de sécurité les plus récentes and garanties untravail sûr et fiable. The multimeter is a useful tool for measuring standard measurements, which means that the artisans are in the industrial sector or in the electronics. The TB 317 multimeter is designed to have a large exterior with a classification of CAT IV 1000 V.

Mesures de security

The TB 317 has quitté notre usine dans a parfait état technique de security. Pour le conserver dans this état, the user is tenu de respecter les consignes de sécurité du present mode d'emploi.



Attention!

N'utiliser que les lignes de mesure de sécurité fournies ou des lignes de mesure équivalentes, satisfaisant aux exigences de la même catégorie de mesure.

Pour éviter tout choc électrique, prendre les mesures de precaution requise lorsque des travaux sont effectués avec des tensions supérieures à 120 V (60 V) CC or 50 V (25 V) eff. APPROX. Selon les normes DIN VDE, ces valeurs represent les limits de tension permettant encore un contact. (Les valeurs entre parenthèses s'appliquent, p.ex., dans le secteur médical ou agricultural.)

Avant chaque mesure, s'assurer que les lignes de mesure et l'appareil de contrôle sont en parfait état.

Les lignes de mesure et points d'essai ne peuvent être touchés qu'au level des poignées prévues à cet effet. Toujours éviter de toucher les pointes d'essai.



The control device can also be used in the specific measurements.



Prudence!

Avant chaque utilisation, the good fonctionnement de l'appareil doit être verifié (sur a source of tension connue, p.ex., voir également DIN VDE 0105, batch 1).

Explication of interrupteurs, buttons and prizes

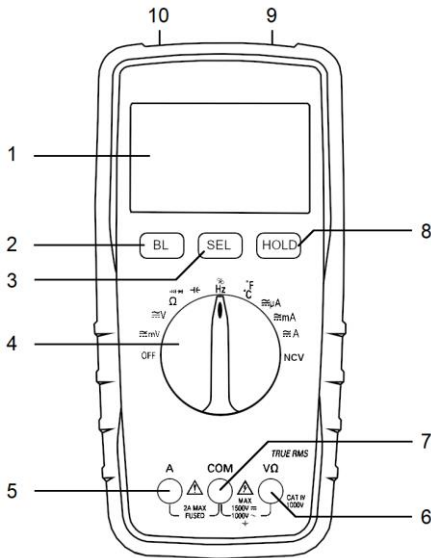

(1) Ecran

(2) Bouton BL

This button activates the rétroéclairage / l'éclairage du point de mesure.

(3) Bouton SEL

This button allows you to change the categories of equipment.

(4) **Selector de fonction** Allume l'appareil. The function of measurement is selected according to the position of the interrupter.

(5) **Prize de mesure A** Prize de mesure à utiliser pour les mesures de courant.

(6) **Prize de mesure V/Ω** Prize de mesure à utiliser pour les mesures de tension / résistance.

(7) Pinch COM / de terre

(8) Bouton HOLD

This button allows you to register the current value on display.

(9) Éclairage du point de mesure

Éclairage du point de mesure sur la face avant de l'appareil permettant de travailler dans les zones sombres.

(10) Capteur NCV

This surface detects the cables sous tension without contact.

Mesure de la tension continue / V=

Control the beach according to your selector's choice. Raccorder the line of measurement black à la pinch «COM» et la ligne de mesure rouge à la pinch «V/Ω». Raccorder les lignes de mesure à l'objet à contrôler. Consulter les résultats de la mesure à l'écran. The polarity of the tension is equal.

plaque de mesure	Resolution	Resistance d'entrée	Protection contre les surtensions	Precision
600mV	0.1 mV	> 1000 MΩ	1500 Vrms	±0.8% of the beach measurement + 4 digits
6V	1 mV	> 10 MΩ		
60V	10 mV			
600V	100 mV			
1000 B	1V			±1% of the beach measurement + 5 digits

Mesure de la tension alternative / V~

Control the beach according to your selector's choice. Appuyer sur le bouton «SEL» et sélectionner CA. Raccorder the line of measurement black à la pinch «COM» et la ligne de mesure rouge à la pinch «V/Ω». Raccorder les lignes de mesure à l'objet à contrôler. Consulter les résultats de la mesure à l'écran.

plaque de mesure	Resolution	Resistance d'entrée	Protection contre les surtensions	Precision
600mV	0.1 mV	> 1000 MΩ	1500 Vrms	±0.8% of the beach measurement + 5 digits
6V	1 mV	> 10 MΩ		
60V	10 mV			
600V	100 mV			
1000 B	1V			±1.5% of the beach measurement + 5 digits

Frequency frequency: 10 Hz - 1.2 kHz

Mesure du courant continu / A=

Control the beach according to your selector's choice. Raccorder the line of measurement black à la pinch «COM» et la ligne de mesure rouge à la pinch «A». Raccorder les lignes de mesure à l'objet and consult the résultat de mesure à l'écran. The sense of courage is also indiqué by the sign.

plague de mesure	Resolution	Protection contre les surtensions	Precision
600µA	0.1µA	200mA	±1.2% of the beach measurement + 3 digits
6000µA	1µA	Fusible à réarmement automatique.	
60mA	10mA		
600mA	100µA		
10A	10mA	10A/1000V	±2.0% of the beach measurement + 10 digits

Respect the maximum duration of the beach at 10 A!

Mesure du courant alternatif / A~

Control the beach according to your selector's choice. Appuyer sur le bouton «SEL» et sélectionner CA. Raccorder the line of measurement black à la pinch «COM» et la ligne de mesure rouge à la pinch «A». Raccorder les lignes de mesure à l'objet and consult the résultat de mesure à l'écran.

plague de mesure	Resolution	Protection contre les surtensions	Precision
600µA	0.1µA	200mA	±1.5% of the beach measurement + 3 digits
6000µA	1µA	Fusible à réarmement automatique.	
60mA	10mA		
600mA	100µA		
10A	10mA	10A/1000V	±3.0% of the beach measurement + 10 digits

Frequency frequency: 10 Hz - 1.2 kHz

Measurement of resistance / Ω



Control the beach according to your selector's choice. Raccorder the line of measurement black à la pinch «COM» et la ligne de mesure rouge à la pinch «V/ Ω ». Raccorder les lignes de mesure à l'objet and consult the résultat de mesure à l'écran.

Plage de mesure	Resolution	Precision
600 Ω	0.1 Ω	± 1.2% + 5 digits
6K Ω	1 Ω	
60K Ω	10 Ω	
600K Ω	100 Ω	
6M Ω	1K Ω	
60M Ω	10K Ω	±2.0% + 10 digits

Protection against voltages: 250 V RMS

Tension à vide: 1.2 V

Test the diode

Control the selector on «  /  ». Appuyer 2x on the button «SEL». Raccorder la ligne de mesure black à la pinch «COM» et la ligne de mesure rouge à la pinch «V/ Ω ».



Raccorder les lignes de mesure à l'objet à contrôler (ligne de mesure rouge = anode, ligne de mesure black = cathode). La tension directe s'affiche.

Plage de mesure	Resolution	Affichage
	1 mV	Tension directe de la diode émettrice

Protection against voltages: 250 V RMS

Tension à vide: 1.0 V

Continuity test

Control the selector on «  /  ». Appuyer sur le bouton «SEL». Raccorder la ligne de mesure black à la pinch «COM» et la ligne de mesure rouge à la pinch «V/ Ω ».

Raccorder les lignes de mesure au circuit à contrôler.

Plage de mesure	Function
	The integrated vibrator has a continuous lower voltage of 50 Ω

Tension à vide: 1.0V

Temperature

Control the selector on «C». Raccorder with a temperature probe of type K (nickel-chrome / nickel) on the prices «V/Ω» et «COM». Consulter les résultats de la mesure à l'écran.

Plage de mesure	Resolution	Precision
- 20 to 0 °C	1°C	± 2% + 3 digits
0 to 400 °C		± 1% + 2 digits
400 to 1000 °C		± 2% + 2 digits
- 4 at 32°F	1°F	± 2% + 6 digits
32 to 752°F		± 1% + 4 digits
752 to 1832°F		± 2% + 4 digits

Measurement of capacity / F

Control the selector on «». Raccorder the line of measurement black à la pinch «COM» et la ligne de mesure rouge à la pinch «V/Ω». Raccorder les lignes de mesure au circuit à contrôler and consult the résultat de mesure à l'écran.

Plage de mesure	Resolution	Precision
60nF	10pF	± 4% + 3 digits
600nF	100pF	
6μF	1nF	
60μF	10nF	
600μF	100nF	
6mF	1μF	
60mF	10μF	



Décharger les condensateurs avant chaque mesure.

Frequency

Control the selector on «Hz». Raccorder the line of measurement black à la pinch «COM» et la ligne de mesure rouge à la pinch «V/Ω». Raccorder les lignes de mesure au circuit à contrôler and consult the résultat de mesure à l'écran.

Plage de mesure	Resolution	Precision
10Hz	0.001Hz	± 1% + 5 digits
100Hz	0.01kHz	
1kHz	0.1Hz	
10kHz	1Hz	
100kHz	10Hz	
1MHz	100Hz	
10MHz	1kHz	

Protection against voltages: 250 V RMS

Factor de cycle

Control the selector on «%Hz». Appuyer sur le bouton «SEL». Raccorder the line of measurement black à la pinch «COM» et la ligne de mesure rouge à la pinch «V/Ω». Raccorder les lignes de mesure au circuit à contrôler and consult the résultat de mesure à l'écran.

Plage de mesure	Resolution	Precision
0 – 99%	0.1%	± 3% + 2 digits

Protection against voltages: 250 V RMS

Arrêt automatic

The apparatus is automatically activated après env. 15 minutes (APO). Un appui long sur le bouton «HOLD» pendant the allumage active la fonction d'arrêt automatique. Un appui long sur le bouton «SEL» pendant the allumage deactivates the automatic arrest function.

Retro éclairage

Appui sur le bouton «BL» active le rétroéclairage.

L'éclairage s'éteint automatiquement après env. 15 seconds. If the bouton remains enfoncé plus longtemps, the éclairage du point de mesure s'allume.

Fonction d'enregistrement (HOLD)

The device arrives so easily in the positions of the measurements that are uncomfortable. Appui sur le bouton «HOLD» Permet de geler la valeur de mesure current qui peut alors être lue lorsque les conditions sont plus favorables.

A new appui on the button «HOLD» You can return to normal measurement mode.

True RMS

In cases of measurements of non-sinusoidal signals, the errors in measurements can be monitored by the use of the "True RMS" function and inférieures à celles of the procedures of measurement traditions.

The sinusoidal signals are not measured precisely in the "True RMS" function.

Entretien

S'il est utilisé conformément aux instructions de service, the apparatus is also required.

Net yage

The device is suitable for the use of the quotidienne, it is net with a chiffon humide and a piece of detergent ménager doux. Ne jamais utiliser de produits agressifs or solvants pour le nettoyage.

Replacing the pile

Immediately replace the piles with the symbols of the piles Débrancher l'appareil à l'écran. lines of measurement of the equipment before replacing the piles!

From the equipment you can see, you can save the piles and unload the pile. Mettre de new piles en place (1 × 9V bloc). Put the cover in the compartment with piles in place and be visible.



Utiliser exclusivement les piles indiquées!

The piles can be poured into the order ménagères! Respect the legal prescriptions for elimination!

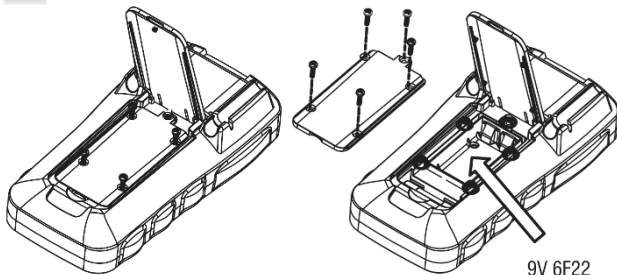

Remplacement of the fusibles

Retire the vis se trouvant au dos de l'appareil, ouvrir the compartiment à piles, retirer the pocket holster, les vis du boîtier et le fusible. Mettre un new fusible (F 10A) en place. Reassemble the equipment in the reverse order and keep it visible.



Utiliser exclusivement les fusibles indiqués !

The following measuring categories are defined according to the standard EN 61010-1:

Catégorie de mesure CAT II

Mesures réalisées sur les circuits électriques raccordés directement au réseau via a fiche, pour un usage ménager, dans les bureaux et laboratoires.

Catégorie de mesure CAT III

Mesures réalisées at the level of installations électriques interiors: consommateurs stationnaires, raccordement répartiteur, appareils encastrés dans le répartiteur.

Catégorie de mesure CAT IV

Mesures réalisées à la source de l'installation basse tension: compteur, protection primaire contre les surintensités, raccordement principal

Characteristic techniques

Measurement of the tension continues	0V~1000V
Mesure the tension alternative	0V~1000V
Mesure du courant continu	0A ~ 10A
Mesure du courant alternative	0A ~ 10A
Measurement of resistance	0Ω ~ 60MΩ
Control of continuity	0Ω ~ 50Ω
Measurement of the temperature	- 200°C ~ 1300°C - 328°F ~ 2372°F
Measurement of frequency	10Hz~10MHz
Fusibles	Fusible with automatic activation F 200 mA (without maintenance) and F 10 A (10.3 x 38 mm)
Affichage de la polarité	Automatic
Indicateur de dépassement	"OL" is affiché
Catégorie de surtension	CAT IV 1000V
Alimentation en courant	1 x Bloc 9V
Service temperature	0°C to 40°C
Stockage temperature	- 10°C to 50°C
Dimensions	193 x 95 x 57mm
Poids	500 g with piles

Advice

Indicaciones de seguridad



ADVERTENCIA

The fuentes de riesgo son, por ejemplo, piezas mecánicas podrían causar lesiones graves a personas.

Existe también riesgo para objetos (p. ej. daños en el instrumento).



ADVERTENCIA

Una descarga eléctrica podría causar the death or lesions graves a personas, así como ser una amenaza para el funcionamiento de objetos (p. ej. daños en el instrumento).



ADVERTENCIA

No direct or indirect laser rays are used, with reflecting superficies that have a lot of eyes. The rayo laser can cause daños irreparable in the eyes.

To obtain medication for people, you can deactivate the laser beam.

General safety indicators



ADVERTENCIA

For reasons of safety and homologation (CE), it is not possible to transform and make modifications to the instrument. A fin de garantizar un funcionamiento seguro del instrumento, es imprescindible cumplir las indicaciones de seguridad, las notas de advertencia y el capítulo "Uso previsto".



ADVERTENCIA

Before using the instrument, you should read the following indications:

Evite the use of the instrument in the mediation of electrical solders, heaters for induction and other electromagnetic fields.

Después de cambios de temperatura bruscos, antes de usar el instrumento deberá aclimatarse durante aprox. 30 minutes to the new ambient temperature with the infrared sensor stabilized.

No exposure of the instrument lasts much longer than high temperatures.

Evite an entorno with pole and humedad.

¡Los instruments de medición y los accesorios no son a toy y no deben dejarse alcance de niños!

The industrial installations are teners in accordance with the standards for preventing accidents from professional competent professionals in preventing accidents in laboratories for electrical installations and equipment.



Tenga en cuenta las cinco reglas de gold en electricidad:

- 1Desconexión, corte efectivo.
- 2Prevenir cualquier posible realimentación. Bloqueo y señalización.
- 3Verificar la ausencia de tensión (debe determinarse en dos polos).
- 4Puesta a tierra y cortocircuito.
- 5Señalización de la zone de work.

Uso previsto

The instrument has been previsto only for the user's descriptions and the manual of instructions. Está prevento cualquier other uso. This can cause accidents or destroy the instrument. This results in an immediate cancellation of the fault or reclamation by the manufacturer's guarantee.



To protect the instrument from time to time, you can use the instrument over a long period of time.



In the case of production of daños en la integridad física de las personas or daños materiales ocasionados por una manipulación inadecuada or por el incumplimiento de las indicaciones de seguridad, no asumimos ninguna responsabilidad. In these cases, the cancellation is due to the guarantee. A symbol of exclamación dentro de un triángulo hace referencia las indicaciones de seguridad en el manual de instrucciones. Antes de la puesta en servicio, le el manual al completo. This instrument is available for homologation CE and cumple, for tanto, the directives required.

We reserve the right to make modifications and specifications in advance notice © 2022 Testboy GmbH, Germany.

Cláusula de exención de responsabilidad



¡Los derechos por garantía quedan anulados cuando los daños han sido products por incumplimiento del manual! ¡No asumimos ninguna responsabilidad por los daños derivados resultantes!

Testboy is not responsible for the results of the results: | El incumplimiento del manual.

|The product modifications are not authorized by Testboy |The parts are not manufactured or authorized by Testboy |The work includes the effects of alcohol, drugs and medications.

Exactity of the manual instructions

This manual of instructions has been redacted with a large size. No guarantee is given for the accuracy and integrity of the data, the images are not printed. Reserve the derecho to realize modifications, correct erratas and errors.

Gestion de residuos

Estimado cliente de Testboy, with the acquisition of the new product tied to the posibilidad -una very finalizada su vida útil- devolver el instrumento a los puntos de recogida selectiva adecuados para chatarra eléctrica.



The Directiva RAEE regulates the recogida and the reciclaje of residuos de aparatos eléctricos y electrónicos. The fabricators of electrical appliances are obligatory to receive and receive in free form the electrical appliances sold. The electrical appliances are not compatible with the "normal" residual fluids. The electrical appliances should be recycled and eliminated separately. All devices are affected by this directive and the logotype.

Elimination of the piles used



Usted, as usual final, it is obligatory for only a return to the piles and batteries used (**Legislación sobre pilas y acumuladores**). **¡Está prohibido desecharlas en la basura domestica!**

The pilas/baterías with sustancias nocivas aretán marcadas with the symbols indicated in the margins. It should be noted that the prohibition of desecharlas in the domestic base.

The symbols of the metal pieces determine the following: **CD**=cadmio, **Ed**=mercury, **Pb**=plomo.

Podrá enter las pilas/baterías usadas en los puntos de recogida selectiva de su municipio o en cualquier comercio que venda pilas/baterías. ¡Todo ello sin ningún coste adicional para usted!

Certificado de calidad

These activities and processes are related to the quality achieved by Testboy GmbH and are controlled by the permanent median form and the quality control system. The company Testboy GmbH certifies that the devices for revision and the instruments used during the calibration are in some cases under permanent control for equipment for inspection, medicine and analysis.

Declaration of conformity

ElPer ducto cumple las directivas más recientes. Find more information on www.testboy.de

Manejo

Introduction

El Testboy®TB 317 is a universal multimeter. This instrument of medicine has been manufactured by acuerdo at the latest standards of safety and security and is safe and reliable. The multimeter is, tanto en ámbito commercial como industrial, así como para electrónicos, una valiosa ayuda en todas las tareas comunes de medición. The TB 317 multimeter is also equipped with a CAT IV 1000V classification.

Medidas de seguridad

The TB 317 has a solid fabrication and a perfect technical level with safety reference. Para mantener este estado, el usuario deberá respetar las indicaciones de seguridad incluidas en estas instructions.



¡Atencion!

Use only the cables de medición de seguridad suministrados or cables equivalentes that correspond to the misma categoría de medición.

To remove the electric charge, you can use the preventive devices to work with higher voltages such as 120 V (60 V) CC or 50 V (25 V) CA effectively. These values representan, según la DIN VDE, the limit of the voltages expuestas. (Los valores between paréntesis son validos para, por ejemplo, ámbitos médicos or agrícolas.)

Antes de cada medición, asegurarse de que los cables de medición y el instrumento de comprobación están en perfecto estado.

The cables of medicine and the points of testing can only be used to prepare the mangoes beforehand. You have to make contact with the points of testing that are important for the circuit.



The instrument for comprobación alone should be used in the specific medicines.



¡Atencion!

Before you use it, you need to revise the instrument to check the correct functioning (p. ej. in a fuente de tensión conocida, ver también DIN VDE 0105, sección 1).

Description of interruptors, pulsers and casquillos

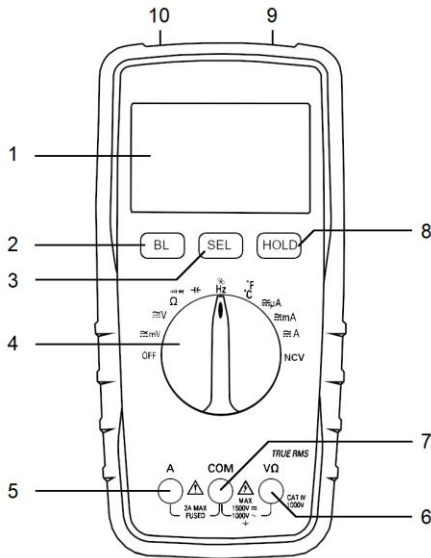

(1) Pantalla

(2) Tecla BL

The pulse of the device activates the illumination of the background/the points of medicine.

(3) Tecla SEL

This device allows you to change the categories instrumento.

(4) Interruptor selector de función de medición

Activa el instrumento. The function of the medication is indicated by the position of the interruptor.

(5) Manguito de medición A

Manguito de medición a usar en mediciones de corriente.

(6) Manguito de medición V/Ω

Manguito de medición a usar mediciones de tensión y resistance.

(7) COM/Casquillo a masa

(8) Tecla HOLD

This tecla permite guardar el valor mostrado actualmente.

(9) Illumination of points of medicine

Illuminación de puntos de medición en la parte delantera para trabajar en áreas oscuras.

(10) NCV sensor

This superficie detecta sin contacto conductos con tension.

Medición de tensión continua / V=

Adjust the range using the convertor selector. Connect the black medication cable to the casquillo «COM» and the cable de medicine red with the casquillo «V/Ω». Connect the medication cables to the control piece. There are no results of medication on the screen. This indicates the polarity of the tension.

Margins de medication	Resolution	Resistance de entrada	Protection de sobretension	Precision
600mV	0.1mV	> 1000 MΩ	1500 Vrms	±0.8% of medication margins + 4 digits
6V	1mV	> 10 MΩ		
60v	10mV			
600V	100mV			
1000 B	1V			±1% of medication margin + 5 digits

Medición de tensión alterna / V~

Adjust the range using the convertor selector. Pulsar la tecla «SEL» y select AC. Connect the black medication cable to the casquillo «COM» and the cable de medicine red with the casquillo «V/Ω». Connect the medication cables to the control piece. There are no results of medication on the screen.

Margins de medication	Resolution	Resistance de entrada	Protection de sobretension	Precision
600mV	0.1mV	> 1000 MΩ	1500 Vrms	±0.8% of medication margins + 5 digits
6V	1mV	> 10 MΩ		
60V	10mV			
600V	100mV			
1000 B	1V			±1.5% of medication margins + 5 digits

Frequency range: 10 Hz - 1.2 kHz

Medición de corriente continua / A=

Adjust the range using the convertor selector. Connect the black medication cable to the casquillo «COM» and the cable de medicine red with the casquillo «A». Connect the cables of medication to the piece of control and empty the result of the medication on the screen.

También se indicará el sentido de la corriente mediante signos.

Margins de medication	Resolution	Protection de sobretension	Precision
600µA	0.1µA	200mA	±1.2% of medication margins + 3 digits
6000µA	1µA	Fusible con rearme automatic.	
60mA	10mA		
600mA	100µA		
10A	10mA	10A/1000V	±2.0% of medication margins + 10 digits

¡Tener en cuenta el tiempo de conexión máximo en el range 10 A!

Medición de corriente alterna / A~

Adjust the range using the convertor selector. Pulsar la tecla «SEL» y select AC. Connect the black medication cable to the casquillo «COM» and the cable de medicine red with the casquillo «A». Connect the cables of medication to the piece of control and empty the result of the medication on the screen.

Margins de medication	Resolution	Protection de sobretension	Precision
600µA	0.1µA	200mA	±1.5% of medication margins + 3 digits
6000µA	1µA	Fusible con rearme automatic.	
60mA	10mA		
600mA	100µA		
10A	10mA	10A/1000V	±3.0% of medication margins + 10 digits

Frequency range: 10 Hz - 1.2 kHz

Medición de la resistance / Ω



Adjust the range using the convertor selector. Connect the black medication cable to the casquillo «COM» and the cable de medicine red with the casquillo «V/ Ω ». Connect the cables de medication to the piece of control and empty the result of the medication on the screen.

Margins of medication	Resolution	Precision
600 Ω	0.1 Ω	±1.2% + 5 digits
6K Ω	1 Ω	
60K Ω	10 Ω	
600K Ω	100 Ω	
6M Ω	1K Ω	
60M Ω	10K Ω	±2.0% + 10 digits

Protection from sobretension: 250 V RMS

Tension of voltage on vacuum: 1.2 V

Test de diodes



Poner the convertor selector in  / . Pulsar 2 veces the tecla «SEL». Conectar The black medication cable with the casquillo «COM» and the cable de medicine red with the casquillo «V/ Ω ». Connect the cables de medicine with the pieza de control (cable de medicine rojo = anodo, cable de medicine negro = catodo). It increases the direct tension.

Margins of medication	Resolution	Indication
	1mV	Direct tension

Protection from sobretension: 250 V RMS

Tension of voltage on vacuum: 1.0 V

Continuity check

Poner the convertor selector in  / . Pulsar la tecla «SEL». Connect the cable de medición negro with el casquillo «COM» and the cable de medicine red with the casquillo «V/ Ω ». Connect the medication cables to the control circuit.

Margins of medication	Function
	The Zumbador integrates with the help of 50 Ω

Tension de marc ha en vacío: 1.0 V

Temperatura

Poner the convertor selector in «°C». Connect a temperature sensor type K (níquel-cromo/níquel) to the casquillos «V/Ω"y"COM». There are no results of medication on the screen.

Margins of medication	Resolution	Precision
- 20 hasta 0 °C	1°C	±2% + 3 digits
0 to 400 °C		±1% + 2 digits
400 to 1000 °C		±2% + 2 digits
- 4 hasta 32 °F	1°F	±2% + 6 digits
32 hasta 752 °F		±1% + 4 digits
752 hasta 1832 °F		±2% + 4 digits

Medición de capacidad / F

Poner the convertor selector in «  ». Connect the black medication cable to the electrical cable casquillo «COM» and the cable de medicine red with the casquillo «V/Ω». Connect the medication cables to the testing circuit and empty the resultant medication on the screen.

Margins of medication	Resolution	Precision
60nF	10pF	± 4% + 3 digits
600nF	100pF	
6μF	1nF	
60μF	10nF	
600μF	100nF	
6mF	1μF	
60mF	10μF	



Descargar los condensadores antes de cada medición.

Frecuencia

Poner the convertor selector in «Hz». Connect the black medication cable to the casquillo «COM» and the cable de medicine red with the casquillo «V/Ω». Connect the medication cables to the testing circuit and empty the resultant medication on the screen.

Margins of medication	Resolution	Precision
10Hz	0.001Hz	±1% + 5 digits
100Hz	0.01kHz	
1kHz	0.1Hz	
10kHz	1Hz	
100kHz	10Hz	
1MHz	100Hz	
10MHz	1kHz	

Protection from sobretension: 250 V RMS

Cycle of work

Poner the convertor selector in «%/Hz». Pulsar la tecla «SEL». Connect the black medication cable to the casquillo «COM» and the cable de medicine red with the casquillo «V/Ω». Connect the medication cables to the testing circuit and empty the resultant medication on the screen.

Margins of medication	Resolution	Precision
0 – 99%	0.1%	±3% + 2 digits

Protection from sobretension: 250 V RMS

Automatic desconexion

Transcurridos aprox. 15 minutes, the instrument is disconnected automatically (APO). Manteniendo pulsada la tecla «HOLD» While the power is on, the Auto Power Off function is activated.

Manteniendo pulsada la tecla «SEL» While the power is on, the Auto Power Off function is deactivated.

Illumination of the background

Pulsando la tecla «BL» se connect the illumination of the background.

After 15 seconds the lighting starts automatically. If you press the tecla, you will have the illumination of the points of medicine.

Function of memory (HOLD)

The medical positions are difficult so that no sea is possible to correct the screen. Pulsando la tecla «HOLD» Se congela el valor de medición actual para poder leerlo cómodamente. Volviendo a pulsar la tecla «HOLD» Vuelve al modo de medición normal.

True RMS

Para la medición de formas de onda no sinusoidales se producen menos errores de medición al utilizar la función True RMS que si se utilizan los procedimientos habituales.

The sinusoidal signals and no sinusoidal signals are exactly based on the True RMS function.

Mantenimiento

The device does not need to be maintained throughout the battery service with manual instructions.

Limpieza

If the instrument is examined by the user diary, it can be cleaned with a human hand and a domestic detergent. No use of products for cleaning corrosion or dissolving for cleaning.

Cambiar la pila

It is necessary to change the pile to separate the symbol of the pile  on the screen. ¡Antes de Cambiar the pila, se deben desconectar los cables de medición del instrumento!

Retire the tornillos of the rear part, remove the compartment of the piles and retract the pile using. Colocar pilas nuevas (1 pila de petaca de 9 V). Colocar la tapa del compartment de pilas y atornillar.



¡Utilice únicamente las pilas especificadas!

¡Las pilas no deben desecharse en la basura domestica! ¡Respete las legal standards de elimination of residues!

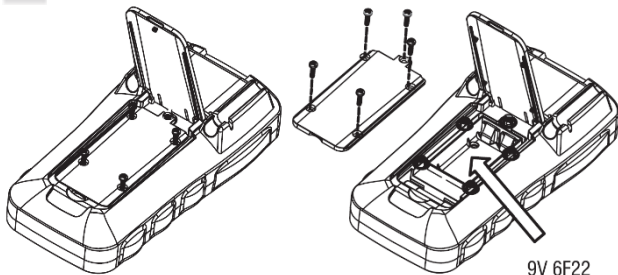

9V 6F22

Cambio de fusibles

Quitar the tornillos of the rear part, abrir the compartment of the piles, quitar the cinta and save the tornillos of the carcasa and the fusible. Colocar un fusible new (F 10A). Turn a colocar and turn on and send it inverso.



¡Utilice únicamente los fusibles especificados!

According to the standard EN 61010-1 there are different categories of medicine:

Category of medicine CAT II

Medicines in circuits that are electrically connected in direct form with red median connectors in the home, the office and the laboratory.

Category of medicine CAT III

Mediciones en la installation del edificio: Consumidores fijos, conexión a distribuidor, instrumentos fijos en el distribuidor.

Categoría de medición CAT IV

Mediciones en la fuente de la installation de baja tensión: Contadores, protección primaria contra sobretensión, conexión principal.

Technical data

Continuous tension medication	0V~1000V
Alternative tension medication	0V~1000V
Continuous medication	0A ~ 10A
Alternating current medication	0A ~ 10A
Medicine for resistance	0Ω ~ 60MΩ
Continuity check	0Ω ~ 50Ω
Medication for temperature	- 200°C ~ 1300°C - 328°F ~ 2372°F
Frequency medication	10Hz ~ 10MHz
Fusibles	F 200 mA with automatic rearrangement (no maintenance required) and F 10 A (10.3 x 38 mm)
Indication of polarity	automatica
Desbordamiento indicator	Se muestra «OL»
Categoría de sobretensión	CAT IV 1000V
Suministro de current	1 pile of 9 V
Service temperature	0°C to 40°C
Almacenamiento temperature	- 10°C to 50°C
Dimensions	193 × 95 × 57mm
peso	500 g pila included

Avvisi

Advice on safety



AVVERTENZA

Fonti di pericolo just like it. Mechanic components can be used to prevent serious personal lesions.

Sussiste also a pericolo di nuni materialsi (ad es. theneggiamento dello instruments).



AVVERTENZA

The folgorazioni electric lettriche possono causare the death or serious lesioni personali, so come theni materiali (ad es. theneggiamento dello instruments).



AVVERTENZA

Don't use the sharp laser, it's not direct, it's not directed at super rifles, against the occhi.

The raggio laser can cause irreparable damage all over the world. In the case of misurazioni eseguite vicino ad altre persone, it is necessary to disactivate the raggio laser.

Avvertenze di sicurezza generali



AVVERTENZA

For reasons of safety and approval (CE), no changes are made and/or arbitrariness of the instruments. To guarantee a safe functioning of the instruments it is absolutely necessary to maintain the safety precautions, with symbols of pericolo and the capitol "Uso regolamentare".



AVVERTENZA

The first way to use the instrument is to use it in separate operating modes:

- | Evitare di usare lo strumento nelle vicinanze di saldatrici electric, impianti di riscaldamento a induzione e other campi electric magnetici.

- | In the case of the bruschi cambi di temperatura, first use the instruments to stabilize for about 30 minutes in the new ambient temperature, according to the condition of the IR sensor.

- | Do not use the instrument for long periods of time to increase the temperature.

- | Evitare l'uso in ambienti polverosi e umidi.

- | The instruments and accessories are not just for children and for children!

- | All internal industrial ambient environments are also monitored by the standard anti-infortunistiche of the associations of categories in material and electrical components.



Before you start the cinque regole di sicurezza:

1Sections complete the impact

2Assicurarsi control the richness and apporre i cartelli di avviso

3Verificare l'assenza di tensione (l'assenza di tensione deve essere verificata sui 2 poli)

4Eseguire la messa a terra e in cortocircuito

5Delimit the zone of lavoro and provide all the protection against the parts active adiacenti

Uso previsto

The instrument is intended to be used to control the operations described in the user manual. Qualsiasi other than us is considered non-previous and can cause immediate or irreparable damage to the instrument. Simili usi causano an immediate cancellation of the warranty concession of the producer all'utente.



The instrument cannot be used for a long period of time, but the battery can be used to protect the device if necessary.



The producer does not assume any responsibility for any possible material or personal derivanti from a uso improprio or dal mancato rispetto delle avvertenze di sicurezza. In the same decade, the direction is all guaranteed. The symbol of the punto esclamativo all'interno di un triangolo richiama l'attention on the avvertenze di sicurezza content nel manuale dell'utente. Prima della messa in funzione, leggere il manuale complete. Questo strumento reca il marchio CE e risponde così a necessarie directive.

The ability to modify the specific sensor according to the prior vision © 2022 Testboy GmbH, Germania.

Exclusion of responsibility



In case of Danni causati dal mancato rispetto del manuale decade qualsiasi diritto alla garanzia! The producer does not assume responsibility for any eventual consequences!

Testboy doesn't answer the Danni che risultano | dal mancato rispetto del manuale dell'utente,

| The modification of the product is not authorized by Testboy or similar | The use of the ricambi is not produced by the Testboy | Dall'uso di alcohol, sostanze stupefacenti or medicinali.

Esattezza del manuale utente

The current manual is now redacted with the maximum possible cure. Ciononostante, non ci assumiamo nessuna responsabilità per l'esattezza né per la completezza dei dati, delle images e dei design. With the help of modifications, corrections and errors.

Smaltimento

Gentili clienti Testboy, with the acquisto of the new product with the possibility of restituire lo strumento - at the appointment of the same cycle of life - and center of raccolta for rifiuti elettronici.



The standard RAEE regulates the restitution and the control of the electronic devices. The manufacturers of electronic devices are therefore obligated to send and receive gratuitamente electronic goods. The electrical appliances do not have enough electricity and are also domestically powered. This devon is made up of riciclati and smaltiti separately. The devices are based on the field of validity of this directive sono contrast with a special march.

Small time to use the battery



The final consumer is tenuto per legge (**legge sulle battery**) a restitution of the battery monouso and ricaricabili used; **This is a small battery in the domestic market!**

The battery monouso/ricaricabili sono contrastsenate with the symbol that a fianco, which richiama l'attenzione su divieto di smaltimento insieme ai rifiuti domestici.

The code that identifies the metal contained in the battery is as follows: **CD** =cadmio, **Ed**=mercury, **Pb**=piombo.

The monouso/ricaricabili battery can be used freely and is freely available in the center of the raccolta del comune di residence oppure in both and points of vendita di battery!

Certificate of quality

This activity is a process that is carried out internally by Testboy GmbH and ensures that the quality is permanently monitored by a system for assuring the quality. The Testboy GmbH confers information on the devices and the instruments used for the taratura sono soggetti and a permanent monitor.

Dichiarazione di conformità

The product conforms to all directives very recently. Maggiori informazioni also available all'indirizzo www.testboy.de

Uso

Introduction

Lo strumento Testboy®TB 317 is a universal multimeter. The instrument of the misura, constructed second to the ultimate standard of security, guarantees a safety and security assurance. This is a set of devices from the industry and the industry, located in the source of the electronics, the multimeter is a valid and valuable instrument for controlling the same problem. Thanks to the CAT IV 1000V class, the TB 317 multimeter also indicates the fault in yesterday.

Misure di sicurezza

The tool TB 317 ha lasciato the fabric in conditions technical ineccepibili. Per mantenere inalterate these conditions, the user can keep the safe content in this manual.



Attention!

Use exclusively in the cavi di misura di sicurezza forniti in dotazione or cavi equivalenti che rispondono alla stessa categoria di misura.

To use the electrical components, you must prepare the necessary components when working with higher voltages at 120 V (60 V) DC or 50 V (25 V) eff. AC. Questi valori sono the tensioni massime di contatto secondo la normativa DIN VDE (i valori tra parentesi si riferiscono ad es. al settore medico o agricolo).

Prima di ogni misura, accertarsi che i cavi di misura and lo strumento si trovino in perfetto stato.

I cavi di misura ei puntali possono essere toccati solo afferrandoli nei punti previsti. Evitare assolutamente di toccare i puntali.



The instrument of the instrument can be used only on the internal part of the façade of the instrument specific.



Attention!

Prima di ogni utilizzo, accertarsi che la norma DIN VDE 0105, parte 1.

Interruttori, keys and porte dello instruments

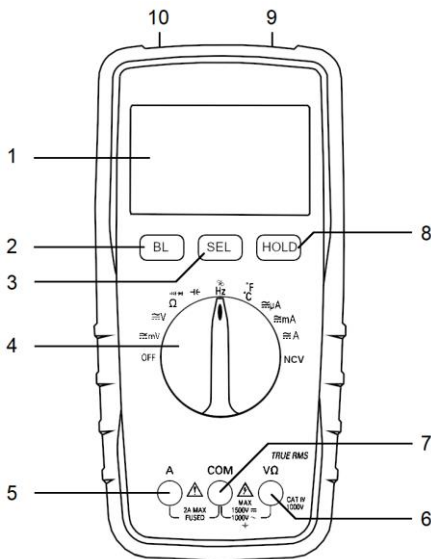

(1) Display

(2) Tasto BL

First of all, you should try to access the retroillumination / the illumination of the point of misura.

(3) Touch SEL

Before you do this, you can change the category of instruments.

(4) Selettore delle funzioni di misura

Before you do this, you can continue to use the instrument.

Ruotare il selettore per selezionare the functions of misura desiderata.

(5) Porta A

Porta da utilizzare per misurare la current.

(6) Porta V/Ω

Porta da utilizzare to manage the tensione / resistance.

(7) COM/Massa

(8) Touch HOLD

Questo tasto permette di salvare il valore attualmente visualizzato.

(9) Illumination of the point of misura

Illumination of the point of misura situata in position frontale per lavorare in zone buie.

(10) NCV sensors

Questa superficie rileva senza contact the presence of cavi sotto tensione.

Misurare la tensione continua / V=

Ruotare il selettore per selezionare the fascia di misura desiderata. Collegare il cavo di misura nero alla porta "COM" The cavo di misura rosso alla porta "V/Ω" from the instrument. Collegare i cavi di misura al componente da misurare. Leggere the result of the misura sul display. The display can be visualized even with the polarity of the voltage.

Campo di misura	Resolution	Impedenza d'ingresso	Scaricatore	Precision
600mV	0.1mV	> 1000 MΩ	1500 Vrms	±0.8% of the campo di misura + 4 cifre
6V	1mV			
60V	10mV			
600V	100mV			
1000 B	1V			±1% of the campo di misura + 5 cifre

Misurare la tensione alternata / V~

Ruotare il selettore per selezionare the fascia di misura desiderata. Premere il tasto "SEL" e selezionare AC. Collegare il cavo di misura nero alla porta "COM" The cavo di misura rosso alla porta "V/Ω" from the instrument. Collegare i cavi di misura al componente da misurare. Leggere the result of the misura sul display.

Campo di misura	Resolution	Impedenza d'ingresso	Scaricatore	Precision
600mV	0.1mV	> 1000 MΩ	1500 Vrms	±0.8% of the campo di misura + 5 cifre
6V	1mV			
60V	10mV			
600V	100mV			
1000 B	1V			±1.5% of the campo di misura + 5 cifre

Frequency gamma: 10 Hz - 1.2 kHz

Misurare la current continua / A=

Ruotare il selettore per selezionare the fascia di misura desiderata. Collegare il cavo di misura nero alla porta "COM" The cavo di misura rosso alla porta "A" from the instrument. Collegare i cavi di misura al componente da misurare, e leggere the result of the misura sul display. The value of the value indicates the direction of the current.

Campo di misura	Resolution	Scaricatore	Precision
600 μ A	0.1 μ A	200mA fusibile authori- pristine.	\pm 1.2% of the field of misura + 3 cifre
6000 μ A	1 μ A		
60mA	10mA		
600mA	100 μ A		
10A	10mA	10A/1000V	\pm 2.0% of the field of misura + 10 cifre

Nella fascia 10 A, osservare the massima durata di funzionamento!

Misurare la current alternata / A~

Ruotare il selettore per selezionare the fascia di misura desiderata. Premere il tasto "SEL" e selezionare AC. Collegare il cavo di misura nero alla porta "COM" The cavo di misura rosso alla porta "A" from the instrument. Collegare i cavi di misura al componente da misurare, e leggere the result of the misura sul display.

Campo di misura	Resolution	Scaricatore	Precision
600 μ A	0.1 μ A	200mA fusibile authori- pristine.	\pm 1.5% of the field of misura + 3 cifre
6000 μ A	1 μ A		
60mA	10mA		
600mA	100 μ A		
10A	10mA	10A/1000V	\pm 3.0% of the field of misura + 10 cifre

Frequency gamma: 10 Hz - 1.2 kHz

Misurare the resistance / Ω



Ruotare il selettore per selezionare the fascia di misura desiderata. Collegare il cavo di misura nero alla porta "COM" The cavo di misura rosso alla porta "V/ Ω " from the instrument. Collegare i cavi di misura al componente da misurare. e leggere the result of the misura sul display.

Campo di misura	Resolution	Precision
600 Ω	0.1 Ω	±1.2% + 5 cifre
6K Ω	1 Ω	
60K Ω	10 Ω	
600K Ω	100 Ω	
6M Ω	1K Ω	
60M Ω	10K Ω	±2.0% + 10 cifre

Scaricatore: 250 V RMS

Tensione a vuoto: 1.2 V

Test diodi



Ruotare il selettore in posizione "  / . Premere 2 volte il tasto "SEL". College il cavo di misura nero alla porta "COM" The cavo di misura rosso alla porta "V/ Ω " from the instrument. Collegare i cavi di misura al componente da misurare (cavo di misura rosso = anodo, cavo di misura nero = catodo). You can visualize the direct tension.

Campo di misura	Resolution	display
	1mV	Direct tension

Scaricatore: 250 V RMS

Tensione a vuoto: 1.0 V

Continuous test

Ruotare il selettore in posizione "  / . Premere il tasto "SEL". Collegare il cavo di misura nero alla porta "COM" The cavo di misura rosso alla porta "V/ Ω " from the instrument. Collegare i cavi di misura al circuito da misurare.

Campo di misura	Function
	The cylinder integrates with an inferior passaggio a 50 Ω

Tension a vuot o: 1.0V

Temperatura

Ruotare il selettore in posizione "°C". Collegare una sonda di temperatura type K (nichelcromo / nichel) alle porte "V/Ω" e "COM". Leggere the result of the misura sul display.

Campo di misura	Resolution	Precision
- 20 / 0°C	1°C	±2% + 3 cifre
0 / 400°C		±1% + 2 cifre
Since 400 a 1000 °C		±2% + 2 cifre
- 4/32°F	1°F	±2% + 6 cifre
32/752°F		±1% + 4 cifre
752 / 1832°F		±2% + 4 cifre

Misura della capacity / F

Ruotare il selettore in posizione "  ". Collegare the cavo di misura nero alla porta "COM" The cavo di misura rosso alla porta "V/Ω" from the instrument. Collegare i cavi di misura al circuito da misurare. e leggere the result of the misura sul display.

Campo di misura	Resolution	Precision
60nF	10pF	± 4% + 3 cifre
600nF	100pF	
6μF	1nF	
60μF	10nF	
600μF	100nF	
6mF	1μF	
60mF	10μF	



Scaricare i capacitors prima della misura.

Frequenza

Ruotare il selettore in posizione "Hz". Collegare il cavo di misura nero alla porta "COM" The cavo di misura rosso alla porta "V/Ω" from the instrument. Collegare i cavi di misura al circuito da misurare, e leggere the result of the misura sul display.

Campo di misura	Resolution	Precision
10Hz	0.001Hz	±1% + 5 cifre
100Hz	0.01kHz	
1kHz	0.1Hz	
10kHz	1Hz	
100kHz	10Hz	
1MHz	100Hz	
10MHz	1kHz	

Scaricatore: 250V RMS

Cyclo di lavoro (Duty Cycle)

Ruotare il selettore in posizione "%/Hz". Premere il tasto "SEL". Collegare il cavo di misura nero alla porta "COM" The cavo di misura rosso alla porta "V/Ω" from the instrument. Collegare i cavi di misura al circuito da misurare, e leggere the result of the misura sul display.

Campo di misura	Resolution	Precision
0 - 99%	0.1%	±3% + 2 cifre

Scaricatore: 250V RMS

Spegnimento automatico

After about 15 minutes the power is automatically activated (function APO). Durante l'accensione dello strumento, first a lungo il tasto "HOLD" to activate or disable the Auto Power Off function. "Premere a lungo il tasto "SEL" Durante l'accensione dello strumento per disattivare la funzione Auto Power Off.

Retroillumination

Premere il tasto "BL" by accendere la retroilluminazione.

After about 15 seconds the illumination is automatically activated. First, listen to the taste while accelerating the illumination of the point of misura.

Function of memory (HOLD)

If you can't access it, it's difficult to see the display. Premere il tasto "HOLD" by "congelare" the value of the misura attuale e leggerlo in all comfort. First new taste "HOLD" per tornare alla modalità operativa normal.

True RMS

Durante the measurement in a non-sinusoidal form, using the True RMS function the precision of the measurement and inferior rispetto ai methods of measurements tradizionali.

Grazie alla True RMS functionality, i have sinusoidal and non-sinusoidal possono but misurati con precisione.

Manual

It is used in conformity with all components contained in the manual, but the instrument does not require a specific manual.

Pulizia

The instrument should be sporcarsi in seguito all'uso quotidiano, pulirlo with a panno umido and a po' di detergent domestico delicious. Evitare the use of aggressive detergents or solvents.

Substitution of the battery

Immediately install the battery when on the display compare the symbol of . Great so- the battery and it needs to be trained in the instrument panel!

Svitare the life situate sul retro of the instrument, before the vano battery and rimuovere the battery scarica. Insert the new battery (1 battery of 9V). Chiudere the battery pack and recharge the life.



Use only the battery specificate!

The battery does not have enough smaltite and is also domestic! Keep the smaltimento standard in vigor!

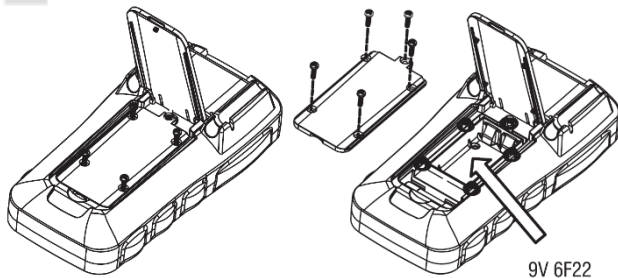

Sostituire il fusibile

Svitare the life situate sul retro dello strumento, aprire the vano battery, rimuovere the battery, svitare the life of the portafusibile and rimuovere the fusibile. Inserire the new fusibile (F 10A). Rimontare and riavvitare nell'ordine inverso.



Use only and fusibili specificati!

According to the EN 61010-1 standard, the different categories of misura are defined:

Category of misura CAT II

Misure su circuiti electrical collegati directtamente alla rete electricala with connections in home, ufficio and laboratorio.

Category of misura CAT III

Misure all'interno delle installations dell'edificio: utenze stazionarie, collegamento del ripartitore, apparecchi collegati fissi al ripartitore.

Category of misura CAT IV

Misure alla fonte dell'installazione a bassa tensione: contatore, scaricatore primario, collegamento principale

Technical data

Misura della tensione continua	0V~1000V
Misura della tensione alternata	0V~1000V
Misura della current continua	0A ~ 10A
Misura della current alternata	0A ~ 10A
Misura della resistance	0Ω ~ 60MΩ
Continuous test	0Ω ~ 50Ω
Misura della temperaturea	- 200°C ~ 1300°C - 328°F ~ 2372°F
Misura della frequency	10Hz ~ 10MHz
Fusibili	F 200 mA autoripristinante (esente da manutenzione) and F 10 A (10.3 x 38 mm)
Indication of polarity	Automatica
Overflow	Viene visualizzato "OL"
Classe di sovratensione	CAT IV 1000V
Electrical supply	1 battery rettangolare da 9 V
Temperatura d'esercizio	Since 0°C a 40°C
Stoccaggio temperature	Since -10°C a 50°C
Dimensioni	193 × 95 × 57mm
peso	500 g with battery

Aanwijzingen

Veiligheidsinstructies



WARSCHUWING

Gevarenbronnen zijn bijv. mechanical parts that seriously letsel van people can veroorzaken.

It also belongs to the people (bijv. de damage to the instrument).



WARSCHUWING

An electric shock can cause the damage of even people who are dead and have a device inside for the work of the instrument (bijv. de damage to the instrument).



WARSCHUWING

Direction of the laser beam is not direct from indirect door reflecting oppervlakken op het oog. Laser beaming can cause damage and damage. Bij metingen in the building of mensen with the laser beam uitgeschakeld.

Algemene veiligheidsinstructies



WARSCHUWING

The speech of the veiligheid en toelating (CE) is the self-made ombouwen en/of change of the instrument not toegestaan. Om een veilig bedrijf met the instrument te garanderen moet u in elk geval de veiligheidsinstructies, waarschuwingen en het hoofdstuk 'Doelmatig gebruik' in eight nemen.



WARSCHUWING

To learn how to use the instrument, follow the instructions in eight languages:

- | Vermijd de inzet van the instrument in the building of electrical laser devices, induction heaters and other electromagnetic devices.
 - | If the temperature changes abruptly, the instrument must be used for approx. 30 minutes at a new temperature and adjusted by the IR sensor to stabilize it.
 - | The instrument never lasts longer than it has high temperatures. Vermijd stoffige and vochtige omgevingsvoorwaarden.
 - | Meet instruments and musical instruments that can be played and heard never in the hands of children!
 - | In industrial facilities, the regulations must be taken to prevent ongevallen van de bond van de industriële ongevallenverzekeringen voor electrical installationaties en bedrijfsmiddelen.
-



Believe in vijf veiligheidsregels in eight things:

- 1 Vrijschakelen
- 2 Beveiligen tegen opnieuw inschakelen
- 3 Spanningsvrijheid vaststellen (spanningsvrijheid should be 2-pole vastgesteld)
- 4 Aarden and kortsluiten
- 5 Naburige onder spanning staande delen afdekken

Good use

The instrument is always ready for use in the operation and handling described toepassingen. A different use is not possible and can result in any damage caused to the instrument by the instrument. The toepassingen hebben dead gevolg dat elk right op Garantie en Schadenvergoeding van the operator jegens de Fabrikant onmiddellijk komt te vervallen.



Using the battery on the instrument for a long time will result in damage.



Bij materiële a pity of persoonlijke verwondingen als gevolg van ondeswissene hantering of niet-inachtneming van de veiligheidsinstructies aanvaarden wij geen aansprakelijkheid. In future it will be guaranteed that it will be lost. A user-friendly device in the three-cornered area is based on comprehensive operating instructions. Lees before inbedrijfstelling de handlingiding helemaal door. The instrument is CE-marked and has a direct connection to the frosted direction.

Rights to the specification of the specification for the purposes of the Wijzigen © 2022 Testboy GmbH, Germany.

Uitsluiting van aansprakelijkheid



It's a shame as people don't care about their handling, it's a shame that it won't be guaranteed! For indirect shame as a result of this, we will have a good time!

Testboy is not a good idea for a shame on the part of the people
 | never beware of the handling,
 | The Testboy is not authorized to change the product | The Testboy
 is not manufactured and is not available on the premises | invloed
 van alcohol-, dovende middelen of medicamenten.

Juistheid van de bedieningshandleiding

The operating conditions will be handled very quickly. The juistheid and fullness of the gegevens, afbeeldingen and tekeningen wordt never been guaranteed. Wijzigingen, printing and forgetting beforehand.

processing

Respected Testboy clan, with the aankoop of ons product heeft and de mogelijkheid om the instrument na afloop van zijn levensduur in te leveren op inzamelpunten voor elektroscroot.



WEEE regulates the use and recycling of electrical appliances. Manufacturers of electrical appliances are obliged to recycle and recycle electrical appliances that have been wasted for free. Electrical devices may never have been brought into the 'normal' stream. Electrical devices must be recycled and processed separately. All devices with different directions are marked with the logo.

Afvoer van used batteries/accu's



U als eindverbruiker bent betlijk (**Wet on batteries**) obliges all used batteries and accu's to be delivered; **afvoeren via het huisvuil is verboden!** Batterijen/accu's the bad fabrics covered with zijn marked with the symbols hiernaast, the wijzen op het verbod van afvoeren via het huisvuil. The name for the doors is in black metal: **CD**=cadmium, **Ed**=kwikzilver, **Pb**=lood.

Uw broken battery/accu's kunt u costeloos inleveren bij de inzamelpunten van uw gemeente, of overal waar battery/accu's have been overcooked!

Quality certificate

All quality-relevant trading and processes within Testboy GmbH have been permanently monitored through a quality management system. Testboy GmbH verifies that the timing of the calibration used test equipment and instruments have been onderworpen aan permanente Bewaking van de testingsmiddelen.

Declaration of conformity

The product is based on the most recent guidelines. More information is available on www.testboy.de

Operating

Insuffering

De Testboy®TB 317 is a universally used multimeter. The instrument is vervaardigd according to the new safety regulations and guaranteed safe and secure works. The multimeter is in the industrial environment and is connected to the electrical system with a good response to all standard requirements. Also for good use, the TB 317 multimeter has a CAT IV 1000V classification and is well sent.

Veiligheidsmaatrules

The TB 317 has the factory in veiligheidstechnisch foutloze toestand verlaten. In this case you will have the opportunity to use the safety instructions in the handling area in eight countries.



Opgelet!
Gebruik allen de meegeleverde veiligheidsmeetleidingen of equivalente meetleidingen, die voldoen aan dezelfde meetcategorie.

An electric shock must be taken into account, with a voltage greater than 120 V (60 V) DC or 50 V (25 V) eff. AC wordt worked. These products are in accordance with DIN VDE and the boundaries of the current range can be reached. (Waarden tussen haakjes gelden voor bijv. medische of agrarische omgevingen.)

Make sure that you have met the test instrument in the socket toestand zijn.

The meetings and testing stages may have been extensively packaged to the data beforehand. Het aanraken van de meetstaven moet onder all omstandigheden have been vermeden.



The test instrument may have been tested within the specific meeting areas.



Precautionary!
Before the device was used, it was controlled by the instrument that functions (bijv. aan one bekende spanningsbron, zie also DIN VDE 0105, deel 1).

Verklaring van schakelaars, buttons and buses

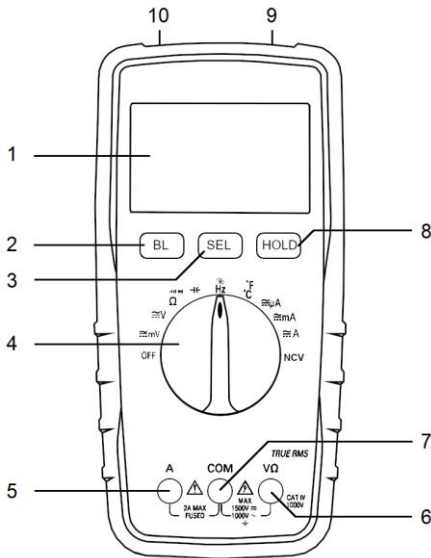

(1) Display

(2) BL toets

Bij active ring of the toets wordt the lighting of the Achtergrond/meetpunten inshaked.

(3) SEL toets

With the same toes, the instrument can be shaken these categories.

(4) Keuzeschakelaar meetfunctie

Shakels the instrument in. Meetfunctie wordt selected for easy access.

(5) Meetbus A

You use meetbus for electricity.

(6) Meetbus V/ Ω

You use meetbus for tensions- /weerstandsmetingen.

(7) COM/Massabus

(8) HOLD toets

With each other you can have a moment had been oppressed.

(9) Verlichting van meetpunten

Aan de voorzijde attached lighting of meetings from the works on donkere plaatsen.

(10) NCV sensor

Dit vlak herkent spanningvoerende Leidingen contactloos.

Gelijkspanningsmeting / V=

With the Keuzeschakelaar the juiste area can be set up. Connect the black meeting with the 'COM'-bus on the road meeting with the 'V/Ω'bus. Connect meetings with the test device. The result is a result of the display. The polarity of the spanning word is even worse.

Meet area	Resoluteness	input weerstand	Overspannings beveiling	Nawkeurigheid
600mV	0.1mV	> 1000 MΩ	1500 Vrms	±0.8% of het meet area + 4 digit
6V	1mV	> 10 MΩ		
60V	10mV			
600V	100mV			
1000 B	1V			

Wisselspanningsmeting / V~

With the Keuzeschakelaar the juiste area can be set up. 'SEL'-knop activate and select AC. Connect the black meeting with the 'COM'-bus on the road meeting with the 'V/Ω'bus. Connect meetings with the test device. The result is a result of the display.

Meet area	Resoluteness	input weerstand	Overspannings beveiling	Nawkeurigheid
600mV	0.1mV	> 1000 MΩ	1500 Vrms	±0.8% of het meet area + 5 digit
6V	1mV	> 10 MΩ		
60V	10mV			
600V	100mV			
1000 B	1V			

Frequency range: 10 Hz - 1.2 kHz

Gelijkstroommeting / A=

With the Keuzeschakelaar the juiste area can be set up. Connect the black meeting with the 'COM'-bus on the road meeting with the 'A'-bus. The meeting will connect with the test of the result and the result will be displayed on the display. The power supply is also available evenly.

Meet area	Resoluteness	Overspannings beveiling	Nawkeurigheid
600 μ A	0.1 μ A	200mA zitzzelf terug-providing zekering	\pm 1.2% of the meeting area + 3 digits
6000 μ A	1 μ A		
60mA	10mA		
600mA	100 μ A		
10A	10mA	10A/1000V	\pm 2.0% of the meeting area + 10 digits

In the 10 A-area maximum inschakelduur in eight times!

Wisselstroommeting / A~

With the Keuzeschakelaar the juiste area can be set up. 'SEL'-knop activate and select AC. Connect the black meeting with the 'COM'-bus on the road meeting with the 'A'-bus. The meeting will connect with the test of the result and the result will be displayed on the display.

Meet area	Resoluteness	Overspannings beveiling	Nawkeurigheid
600 μ A	0.1 μ A	200mA zitzzelf terug-providing zekering	\pm 1.5% of the meeting area + 3 digits
6000 μ A	1 μ A		
60mA	10mA		
600mA	100 μ A		
10A	10mA	10A/1000V	\pm 3.0% of the meeting area + 10 digits

Frequency range: 10 Hz - 1.2 kHz

Weerstandsmeting / Ω

With the Keuzeschakelaar the juiste area can be set up. Connect the black meeting with the 'COM'-bus on the road meeting with the 'V/ Ω ' bus. Connect meetings with the test result and the result of the meeting will be displayed on the display.

Meet area	Resoluteness	Nauwkeurigheid
600 Ω	0.1 Ω	±1.2% + 5 digits
6K Ω	1 Ω	
60K Ω	10 Ω	
600K Ω	100 Ω	
6M Ω	1K Ω	
60M Ω	10K Ω	±2.0% + 10 digits

Overspanningsbeveiliging: 250 V RMS No-load voltage: 1.2 V



Diode test

De keuzeschakelaar instellen op  /  'SEL'. Activate the button twice. The black meetleiding connect met de 'COM'-bus on the road meeting with the 'V/ Ω ' bus. Connect with the test part (rode meetleiding = anode, black meetleiding = cathode). The previous range is worth mentioning.

Meet area	Resoluteness	Indication
	1mV	Voorwaartse spanning

Overspanningsbeveiliging: 250 V RMS No-load voltage: 1.0 V

Doorway test

The kettle can be set up op '  /  'SEL'-knop activate. The black meetleiding connect met de 'COM'-bus on the road meeting with the 'V/ Ω ' bus. Connect with the people and test them.

Meet area	Funcctie
	The integrated signal reports door gang onder 50 Ω

No-load voltage: 1.0V

temperature

The kettle can be set up op '°C'. Sluit a type-K temperature sensor (nikkelchroom / nikkel) on the buses 'V/Ω'en'COM'. The result is a result of the display.

Meet area	Resoluteness	Nawkeurigheid
- 20 to 0 °C	1°C	±2% + 3 digits
0 to 400 °C		±1% + 2 digits
400 to 1000 °C		±2% + 2 digits
- 4 to 32°F	1°F	±2% + 6 digits
32 tot 752°F		±1% + 4 digits
752 dead 1832°F		±2% + 4 digits

Capacity measurement / F

The kettle can be set up op '—|←'. The black meeting place connects with the 'COM'-bus on the road meeting with the 'V/Ω'bus. Connect meetings with the test results and the result will be displayed on the display.

Meet area	Resoluteness	Nawkeurigheid
60nF	10pF	± 4% + 3 digits
600nF	100pF	
6μF	1nF	
60μF	10nF	
600μF	100nF	
6mF	1μF	
60mF	10μF	



The capacitors must be charged before charging.

Frequency

The kettle can be set up on 'Hz'. Connect the black meeting with the 'COM'- bus on the road meeting with the 'V/Ω'bus. Connect meetings with the test results and the result will be displayed on the display.

Meet area	Resoluteness	Nawkeurigheid
10Hz	0.001Hz	±1% + 5 digits
100Hz	0.01kHz	
1kHz	0.1Hz	
10kHz	1Hz	
100kHz	10Hz	
1MHz	100Hz	
10MHz	1kHz	

Overvoltage protection: 250 V RMS

duty cycle

The kettle can be set up on '%Hz'. 'SEL'-knop activate. Connect the black meeting with the 'COM'-bus on the road meeting with the 'V/Ω'bus. Connect meetings with the test results and the result will be displayed on the display.

Meet area	Resoluteness	Nawkeurigheid
0 – 99%	0.1%	±3% + 2 digits

Overvoltage protection: 250 V RMS

Automatic uitschakeling

The instrument uit (APO) shakes for about 15 minutes. Door de 'HOLD'-this time the Auto Power Off function is activated for a long time in the printed word. Than de toets'SEL' 'Tijdens het inschakelen long wordtt indrukt, dan wordt the Auto Power Off functie uitgeschakeld.

Achtergrondverlichting

Door op de 'BL'-Toets te printed wordt de Achtergrondverlichting ingeschakeld. After about 15 seconds the lighting switches on automatically. When the long words are printed, the words are reflected in the meeting point.

Opslagfunctie (HOLD)

The possible meeting positions may not be displayed correctly. Door op de 'HOLD'-toets te printed wordt de actuele meetwaarde bevroren en kan dan gemakkelijk gefgelezen.

Door open on the 'HOLD'-toets te print kert u terug naar het normal meetbedrijf.

True RMS

Bij de meting van niet-sinusvormige golfvormen treden bij gebruik van de True RMS functie lower meetfouten op, zals bij het gebruik van traditonele meetprocedures. Sinusoidal and non-sinusoidal signals can be measured exactly using the True RMS function.

Onderhoud

The instrument can be used in accordance with the handling of the device.

Cleaning

As the instrument for the dagelijk's use has become vuil, then it can be made with a powerful doek and a mildly huishoudelijk cleaning medium. No need for cleaning scissors or cleaning tools used for cleaning.

Batteries lost

The battery should be vervangen as the battery symbol  The display changes. Before the battery is replaced, the instrument must be separated! Schroeven aan de Achterkant widen, battery vak openen and onload battery eruit nemen. New battery (1 x 9V block) in places. The cover of the battery is eroped and sealed.



Use all the batteries!

Batteries never work in the house! Neem de betting regulations in eight!

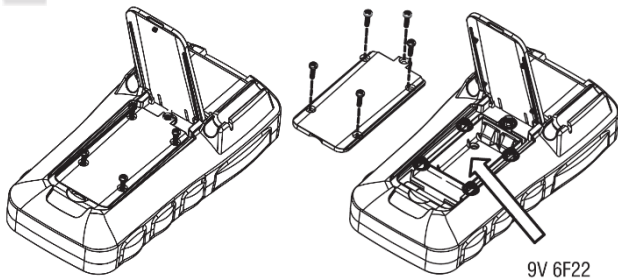

Vervanging van de zekering

The rear edge is widened, the battery is opened, the holster is widened, the rear guard is opened and the battery is opened. Nieuwe zekering (F 10A) erin zetten. In short, the Volgorde has power and a seal.



Use the streets to announce your arrival!

According to the standard EN 61010-1, the following categories have been defined:

Meet category CAT II

Metingen aan stroomkringen the electrical direct with the net zijn connected, via stekkers in house, cantoor and laboratory.

Meet category CAT III

Metingen aan de installatie van gebouwen: stationaire verbruikers, verdeelaansluiting, apparaten vast aan de verdeler.

Meet category CAT IV

Metingen aan de bron van de laagspanningsinstallatie: plates, primary overspanningsbeveiliging, hoofdaansluiting.

Technical countermeasures

Gelijkspanningsmeting	0V~1000V
Wisselspanningsmeting	0V~1000V
Gelijkstroommeting	0A ~ 10A
Wisselstroommeting	0A ~ 10A
Weerstandsmeting	0Ω ~ 60MΩ
Continuity control	0Ω ~ 50Ω
Temperature measurement	- 200°C ~ 1300°C - 328°F ~ 2372°F
Frequency meeting	10Hz ~ 10MHz
Zekeringen	F 200 mA switching (onderhoudsvrij) and F 10 A (10.3 x 38 mm)
Polarity indicator	automatically
Overloop indication	'OL' wordt aangegeven
Overspannings category	CAT IV 1000V
Voeding	1 x 9 V block
Required temperature	0°C to 40°C
Opslag temperature	- 10°C to 50°C
Afmetingen	193 x 95 x 57mm
Weight	500 g including battery



Testboy GmbH
Special electrical engineering
factory at the old airfield 3
D-49377 Vechta
Germany

Tel: +49 4441 89112-10
Fax: +49 4441 84536

www.testboy.de
info@testboy.de