

Belt Tension Meter RTM-400

Measuring range max. 10 - 800 Hz

Trummeter for measuring belt tension and for control the strand force of V-belts, tooth belts, power belts or similar. The optimal life time of a belt is depending on the correct belt tension. The set point for belt tension is specified as natural frequency in Hz or strand force in N.

Non-contact measuring occurs by infrared light - frequency measurement



Belt tension meter RTM-400 

Special Features

- Measuring principle: Frequency measurement by LED light, if the belt is stationary
- The readings can be displayed as frequency (Hz) or strand force (N or lbf)
- The belt tension meter RTM includes a display unit as well as 2 measuring probes:
 - plug in probe for one-hand operation
 - measuring probe with cable for limited access space
- For determining the spring force in Newton, 2 parameters are needed. Thereby the following restrictions are obtained:
 - free strand length 9.99 m
 - belt mass up to 9.999 kg/m

- Measuring range 10 - 800 Hz
 - Multilingual operator guidance and display (german, english, french, italian, spanisch, portugese, swedish, norwegian, danish, finnish)
 - Manufacturer`s calibration report is included
-

Standard Features

- Easy and save operation
 - Trummeter with rugged, handy plastic housing
 - Microprocessor controlled belt tension meter
 - Measurement with highest precision
-

Photo Gallery



Model RTM-400 inclusive 2 sensors





Available Models

Model	Measuring Range
RTM-400	max. 10 - 800 Hz

Operation

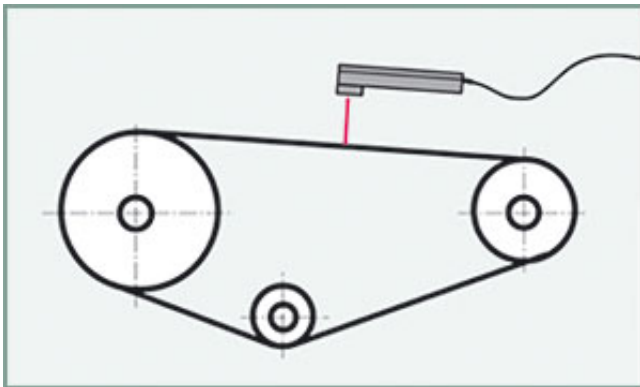

The belt tension can be measured only when the drive is stationary. Preferably, the belt tension should always be measured at the center of the longer belt strand between the two drive pulleys. The distance to the belt can be 5 - 40 mm. Depending upon ambient light and surface of belt, the measurement can occur from a distance of max. 60 mm, whereas darker light and better reflection (can be obtained by attaching a reflective tape) admit a larger measuring distance.

Measurement:

The belt is tapped in order to make it natural oscillating. This static natural frequency is then measured by the probe with the aid of pulsed light. Care must be taken to ensure the light is sufficiently reflected by the belt. A reflective tape must be fixed if necessary.

General information:

To measure the belt mass precisely, we recommend that you weigh the drive belt and then recalculate this weight based on a belt of 1 meter. The strand force is calculated using the formula:

$$T = 4 \cdot m \cdot L^2 \cdot f^2 \quad \text{or} \quad f = \sqrt{\frac{T}{4 \cdot m \cdot L^2}}$$

T = strand force in N

m = linear belt mass in kg/m

L = length of the free belt strand in m

f = natural frequency of the free belt measured in Hz

Note

Measurement deviations of up to ±10 % for several measurements taken on the same drive belt are as a rule not caused by a measurement error or fault in the unit. In most cases, measurement deviations are due to the mechanical tolerances of the drive systems.

Attention! Newton- or poundforce-calculations have a square factor higher error result!

Set point:

The set point for belt tension is specified as natural frequency in Hz or as strand force in N.

It is depending to the characteristics of the drive. Alternative the set point can be calculated with the formula:

$$F = \frac{540 \cdot P \cdot 1.3}{z \cdot v} + k \cdot v^2 \quad \text{[Newton]}$$

P = motor power in kW

z = number of belts

v = speed of belt = $D \cdot n / 19100$

D = effective diameter of the small pulley in mm

n = revolution of the small pulley (Upm)

k·v² = centrifugal force (relevant for revolutions > 800 Upm)

k = Weight of belt in kg/m according the table (for a belt)

Belt Masses

Ribbed V-belts	PJ = 0.082	PL = 0.320	kg/m per 10 ribs
	PM = 1.100		
V-belts	SPZ = 0.074	SPA = 0.123	kg/m per belt
	SPB = 0.195	SPC = 0.377	
	10 = 0.064	13 = 0.109	kg/m per belt
	17 = 0.196	20 = 0.266	
	22 = 0.324	25 = 0.420	
	32 = 0.668	40 = 0.958	
Power belts	SPZ = 0.120	SPA = 0.166	kg/m per rib
	SPB = 0.261	SPC = 0.555	
	3V/9J = 0.120	5 V/15J = 0.252	kg/m per rip
	8V/25J = 0.693		
Polyurethane Tothed belts	T 2.5 = 0.015	T 5 = 0.024	kg/m per 10 mm width
	T 10 = 0.045	T 20 = 0.084	

AT 3 0 0.023

AT 5 = 0.034

AT 10 = 0.063

AT 20 = 0.106

kg/m per 10 mm width

To measure the belt mass precisely, we recommend that you weigh the drive belt and then recalculate this weight based on a belt length of 1 meter.

The table above contains comparison values for some belts.

Delivery Includes



Trummeter with carrying case, 2 measuring probes, 1 battery, manufacturer's calibration report and operating instruction in german or english (as requested)

Specifications

Measuring range:	10 - 800 Hz
Digital sampling error:	< 1 %
Indicator error:	±1 Hz
Total error:	< 5 %
Adjustable measuring units:	Hz (Frequency) or N, lbf (Strand force)
Measuring distance:	3 - 20 mm
Display:	2 line LCD, 16 characters per line
Languages:	10 languages (german, english, french, italian, spanish, portugese, swedish, norwegian, danish, finnish)
Input ranges:	Free strand length: up to 9.99 m Belt mass: up to 9.999 kg/m
Temperature ranges:	Operation: +10 °C ... 50 °C, Transport: -5 °C ... +50 °C
Air humidity:	85 % RH, max.
Power supply:	9 V - Battery
Housing:	Plastic (ABS)
Dimensions:	126 x 80 x 37 (LxWxH)
Weight net (gross):	Approx. 170 g (approx. 660 g)

Specifications subject to change without notice!
